



4<sup>th</sup> December 2019

Your Ref: **AP8/2019**

Our Ref: **T09/511**

Secretary to the Board  
Aquaculture Licences Appeals Board  
Kilminchy Court, Dublin Road  
Portlaoise, Co. Laois.

Dear Mary,

I wish to acknowledge receipt of your letter to Mr. Michael Creed T.D., Minister for Agriculture, Food and the Marine (and copied to Mr. John Quinlan) regarding the appeal against the decision to refuse to grant an Aquaculture and Foreshore Licence to Mr. Kevin Lydon and Mr Patrick Lydon in relation to the above file.

I am attaching the following documentation:-

- T09-511 application form
- Technical and Statutory reports received in relation to the application
- UISCE Report
- Appropriate Assessment Screening – February 2019
- Applicant's response to comments received as a result of the statutory consultation.
- Submission to Minister for Aquaculture Licence and Submission to the Minister for Foreshore Licence
- Notification of Minister's decision to the applicant,
- Publication of the Minister's decision in the Connacht Tribune.

Please note that I am in correspondence with our Marine Engineering Division regarding the location map (showing sites under application, sites lapsed, licensed sites and sites currently under appeal to ALAB) and I will forward same as soon as it is available.

If you require any further information please let me know.  
Please let me have written confirmation of receipt.

Yours sincerely

Ann Mc Carthy

Aquaculture & Foreshore Management Division  
National Seafood Centre, Clogheen, Clonakilty, Co. Cork  
Phone: 023 8859537  
Email: [Ann.McCarthy@agriculture.gov.ie](mailto:Ann.McCarthy@agriculture.gov.ie)

# PLANNING, LEGAL & PUBLIC NOTICES

**GALWAY COUNTY COUNCIL**  
I, Michael O'Grady, intend to apply for planning permission for the construction of a single storey extension at first floor level to the rear of an existing dwelling house at 1 An Leac Uen, Barna, Co Galway, H91 FWSK. The Planning Application may be inspected at the offices of the Planning Authority at the Planning Office, Galway County Council, County Hall, Prospect Hill, Galway during office hours 9:00am to 4:00pm Monday to Friday (Wednesday 10:00 am to 4:00pm). A submission or observation in relation to the application may be made in writing to the planning authority on payment of a fee of €20.00, within the 5 weeks beginning on the date of receipt by the authority of the application, and such submissions or observations will be considered by the planning authority in making a decision on the application. The planning authority may grant permission subject to or without conditions, or may refuse to grant permission. Signed Fergal Bradley & Co. Ltd.

**GALWAY COUNTY COUNCIL**  
We are applying for full Planning Permission on behalf of Jarlath Hennessy to construct a dwelling house and domestic garage with a waste water treatment plant and polishing filter and all associated site works at Castletreevy, Co. Galway. This may be inspected or purchased at the Planning Office, Galway County Council, Prospect Hill, Galway between the hours of 9:00am to 4:00pm Monday to Friday. A submission or observation in relation to the application may be made in writing to the Planning Authority on payment of €20 within 5 weeks of receipt of the application. Signed Padraic Hession & Associates, Consulting Engineers, Unit 5 Galway Technology Park, Parkmore, Galway.

**GALWAY COUNTY COUNCIL**  
Gerald and Louise Garvey are to apply to Galway County Council for planning permission for the construction of a single storey retail building/ pharmacy with consultation room (total floor area circa 200sqm) with associated signage, landscaping, site works and services at the site adjacent to Lakeway Medical Centre, Creggs Road, Glenamaddy Co. Galway. A Nature Impact Statement (NIS) will be submitted to the planning authority with the application. The Planning application may be inspected or purchased at a fee not exceeding the reasonable cost of making a copy, at the offices of the Planning Authority at the Planning Office, Galway County Council, County Hall Prospect Hill, Galway during office hours 9:00am to 4:00pm Monday to Friday (Wednesday 10:00am to 4:00pm). A submission or observation in relation to the application may be made in writing to the planning authority on payment of a fee of €20.00 within the period of 5 weeks beginning on the date of receipt by the authority of the application.

**GALWAY COUNTY COUNCIL**  
Cloonagh, Tuzam  
Full planning permission sought to retain the existing domestic garage full store / workshop area, the garage also has existing attic storage space to be retained (from previous planning permission reference number 06/1471). Full planning permission is also sought to complete the installation of a garage roller door on the south facing elevation and all ancillary site works at the above location on behalf of D Quinn. This may be inspected or purchased at the Planning Office during its public opening hours. A submission or observation in relation to the application may be made in writing on payment of €20 within 5 weeks of receipt of application.

**THE CIRCUIT COURT WESTERN CIRCUIT COUNTY OF GALWAY**  
IN THE MATTER OF THE LICENSING ACTS 1933 - 2000 AND IN PARTICULAR IN THE MATTER OF AN APPLICATION PURSUANT TO SECTION 21(1) OF THE LICENSING (IRELAND) ACT 1902 AS AMENDED BY SECTION 23 OF THE INTOXICATING LIQUOR ACT 1960 AND IN THE MATTER OF THE COURTS (SUPPLEMENTAL PROVISIONS) ACT 1961 AND IN THE MATTER OF AN APPLICATION BY JAMES GLYNN

**NOTICE OF APPLICATION**  
TAKE NOTICE that James Glynn of Dublin Road, Tuam County Galway intend to apply pursuant to Section 21(1) of the Licensing (Ireland) Act 1902 as amended by Section 23 of the Intoxicating Liquor Act 1960, to this Honourable Court sitting at Galway Courthouse in the City of Galway and County of Galway at the sittings thereof commencing at 10:30am in the forenoon of the 6th day of November 2019 or at such time or on such day thereafter as the Application may be made in its order in the Court list, for such certificate as is mentioned in Section 5 of the Licensing (Ireland) Act 1902 enabling me to obtain an Excise Licence commonly called a Seven-Day Publican's Licence to sell intoxicating liquor by retail for consumption on or off the premises known as Fir na Oig (GAP 792) Dublin Road, Tuam in the County of Galway which premises are more particularly described on the plans and drawings accompanying this Application and evidence will be adduced in support of this Application. Dated this 26th day of September 2019. Signed James Glynn. Solicitors: Bruen Glynn & Co Solicitors Dublin Road Tuam County Galway To The Superintendent of An Garda Síochána Tuam County Galway To: The Judge of the District Court, The Courthouse Galway To: The Chief Fire Officer Fr. Griffin Road Galway To: The County Registrar for the County of Galway Galway City

**GALWAY COUNTY COUNCIL**  
Dara Vaughan is applying for full planning permission to construct a dwelling house and a garage with treatment plant and percolation area at Tynone, Kilscligan, Co. Galway. The Planning Application may be inspected or purchased at a fee not exceeding the reasonable cost of making a copy, at the offices of the Planning Authority at the Planning Office, Galway County Council, County Hall Prospect Hill, Galway during office hours 9:00am to 4:00pm Monday to Friday (Wednesday 10:00 am to 4:00pm). A submission or observation in relation to the application may be made in writing to the planning authority on payment of a fee of €20.00, within the 5 weeks beginning on the date of receipt by the authority of the application, and such submissions or observations will be considered by the planning authority in making a decision on the application. The planning authority may grant permission subject to or without conditions, or may refuse to grant permission. Signed Robert Nenas (B Arch), Derrydonnell North, Dranmore, Co. Galway www.robert-nenas.com

We are looking for any Will made by the late Frances Coyne late of Brooklodge Nursing Home Ballygunn, Co. Galway and of Lakeway, Clargawey, Co Galway who died on the 5th of November 2016. Please advise Catherine Hughes at Co. Solicitors, Bishop Street, Tuam, Co. Galway in writing if any on or before the 31st of October 2019.

**GALWAY COUNTY COUNCIL**  
I Aaron Fox wish to apply for Planning permission for the construction of new dwelling along with domestic garage, treatment septic tank system and all associated site works at Carrmore West Dranmore Co Galway. This Planning Application may be inspected or purchased at a fee not exceeding the reasonable cost of making a copy at the Planning Office, Galway County Council, County Hall, Prospect Hill, Galway, during office hours 9:00 am - 4:00 pm, Monday to Friday (Wednesday 10:00 am - 4:00 pm). A submission or observation in relation to the application may be made in writing to the Planning Authority in payment of a fee of €20 within the 5 weeks beginning on the date of receipt by the Authority of the application and such submissions or observations will be considered by the Planning Authority in making a decision on the application. The Planning Authority may grant permission subject to or without conditions or may refuse to grant permission. Signed AARON FOX

**Comhairle Chontae na Gallímhne**  
Is ma'n linn iarratas a dhéanamh ar Chosad Pleanála do Fhorbairt atá comhleáta do na ríthe seo a leanas Uasghrádú ar an bparc imeartha féar atá ann go dtí dromchla saorga uile-aimseire Uasghrádú ar na tuisoíse oiliúna atá ann cheana go áno Coáin tuiscil 20m le soláil go circa 500tuair. Arís súgartha móla do leanaí is éard atá i gceist le forbairt na comartha ar thailé atá ann cheana ián chur na n-íre seo a leanas a chur istu na h-imeartha súimh gaomhara agus an fáil imhine móimhpeall an páirc imeartha agus tíora nua babháil liethrod iad thar do na cúlú nua. Gach ceann ag Láteavew Baile Chiar na Gallímhne Co na Gallímhne. Gur léard an t-iarratas pleanála a scrúdú ná cheannach in oifig an údaráis pleanála agus gur léard sígnheacht nó tuairim maidir leis an iarratas a dhéanamh i scríbhán ar focalocht an tAite atá leagtha síos, iad thar do na cúlú nua. 5 seachtáin i rith uasanta oscailte oifig, 9:00am go 4:00pm. Luan go h-áine ag tobu ar an dáta a luas an tÚdaráis pleanála an t-iarratas, le léard an tógá a chur in aon cheann de na páipéir nuachtá cheadithe seo a leanas agus chomh fada is go ndéanar an páipéar sa cheantar nua bhrúil an fhorbairt móla baile. Síneadh CLG Bhaile Chiar na Gallímhne

**Galway County Council**  
Permission is being sought on behalf of Anne McKinn for full planning permission to (1) renovation of existing derelict dwelling/semi ruinous dwelling as well as all ancillary site works and site services (2) To remove existing unauthorised mobile home at Mannin More, Co Galway. This planning application is accompanied by a NIS, as required by Article 239 of the Planning and Development Regulations, 2001 (as amended). The application may be inspected or purchased at a fee not exceeding the reasonable cost of making a copy at the offices of the Planning Authority at the planning office, Galway County Council, County Building Prospect Hill, Galway during office hours 9:00am to 4:00pm Monday to Friday (Wednesday 10:00am to 4:00pm). A submission or observation in relation to the application may be made in writing to the planning authority on payment of a fee of €20 within 5 weeks beginning on the date of receipt by the Authority of the application. Signed, Enda O'Malley (Chartered Engineer, Tel: 0863567851)

**GALWAY COUNTY COUNCIL**  
Notice to Galway Co. Council Significant Further Information on Planning File Reference No. 19/940 at Carrowmanagh, Oughterard Under Planning Reference No. 19/940 planning permission is being sought by Charles Cormican for the construction of a two storey dwelling house, wastewater system and percolation area and all associated site works at Glann Road, Carrowmanagh, Oughterard, Co. Galway. Significant further information in respect of this planning application has been requested by Galway County Council to include a Flood Risk Assessment and a Nature Impact Statement. The Planning Application may be inspected at the offices of the Planning Authority at the Planning Office, Galway County Council, County Hall, Prospect Hill, Galway during office hours 9:00am to 4:00pm Monday to Friday (Wednesday 10:00 am to 4:00pm). A submission or observation in relation to the application may be made in writing to the planning authority on payment of a fee of €20.00. The planning authority may grant permission subject to or without conditions, or may refuse to grant permission. Signed Fergal Bradley & Co. Ltd

**GALWAY COUNTY COUNCIL**  
I, the undersigned, on behalf of Rosemary and Paul Kavanagh, wish to apply to Galway Co Council for Planning Permission for the extension of an existing dwelling house, construction of a new site entrance with internal access road, installation of a new proprietary effluent treatment system and all associated site works at Ballinacred, Ballynagh, Clifden, Co Galway. The planning application may be inspected or purchased at the offices of the planning authority and a submission or observation in relation to the application may be made to the authority in writing on payment of the prescribed fee within the period of 5 weeks during office opening hours 9:00am to 4:00pm, Monday to Friday beginning on the date of receipt by the authority of the application. Liam Loughrey BE C Eng

**GALWAY COUNTY COUNCIL**  
Permission is sought for (1) new bar and restaurant facade at ground floor level, to include raised lettering and associated lighting (2) replacement of existing high level retail signage to the front elevation along with all associated works at 'The Imperial Hotel' 35 Eyre Square, Galway (or 'Foxfield Inns DAC'). This application may be inspected or purchased at the offices of Galway City Council during its public opening hours and a submission or observation in relation to the application may be made to this authority in writing on payment of the prescribed fee of €20 within the period of 5 weeks beginning on the date of receipt by Galway City Council of the application. Signed c/o Cyril J. Kelly & Associates

**GALWAY COUNTY COUNCIL**  
Planning Permission is sought for the demolition of an existing dwelling and shed, the construction of a dwelling house, garage, stable, tool shed, treatment system and percolation area at Hampstead, Ballymacward, Ballinacree, Co. Galway. This planning application may be inspected or purchased, at a fee not exceeding the reasonable cost of making a copy at the offices of the planning authority: County Hall, Prospect Hill, Galway during public office hours. A submission or observation in relation to the application may be made in writing to the planning Authority on payment of a fee of €20.00, within 5 weeks of receipt by the Authority of the application. Signed Mike & Jennifer Keane

**FISHERIES (AMENDMENT) ACT, 1997 (NO. 23) FORESHORE ACT, 1933 (NO. 12) NOTICE OF DECISION TO GRANT AQUACULTURE AND FORESHORE LICENCES.**  
The Minister for Agriculture, Food and the Marine has decided to grant or refuse to grant Aquaculture and Foreshore Licence applications to the following in the table below in Killyard Harbour, Co. Galway:

Reference Number	Name	Species	Decision
T09/422/1	On-Line Mussels Ltd, C/O Claran Coyle and Pat Lydon, Lettergessh West, Renvyle, Co. Galway	Mussels using longlines	Grant Licence
T09/507	Killary Fjord Shellfish Ltd., Bunowen, Leenane, Co. Galway	Mussels using longlines	Grant Licence
T09/477	Kevin Lydon, Cluggam, Maam, Co. Galway	Mussels using longlines	Refuse Licence
T09/508	Pat Lydon, Lettergessh West, Renvyle, Co. Galway	Mussels using longlines	Refuse Licence
T09/509	Kevin & Michael Lydon, Cluggam, Maam, Co. Galway	Mussels using longlines	Refuse Licence
T09/510	Kevin & Michael Lydon, Cluggam, Maam, Co. Galway	Mussels using longlines	Refuse Licence
T09/511	Kevin & Michael Lydon, Cluggam, Maam, Co. Galway	Mussels using longlines	Refuse Licence

The reasons for these decisions are elaborated on the Department's website at: <http://www.agriculture.gov.ie/seafood/aquacultureforeshoremanagement/aquaculturelicensing/aquaculturelicencedecisions/galway/>

An appeal against the Aquaculture Licence decision may be made in writing, within one month of the date of its publication, to the AQUACULTURE LICENCES APPEALS BOARD, Kilminchy Court, Portlaoise, Co. Laois, by completing the Notice of Appeal Application Form available from the Board, phone 057 86 31912, e-mail [info@alab.ie](mailto:info@alab.ie) or website at <http://www.alab.ie/>

A person may question the validity of the Foreshore Licence determination by way of an application for judicial review, under Order 84 of the Rules of the Superior Court (SI No. 15 of 1986). Practical information on the review mechanism can be obtained from the Citizens Information Board at: <http://www.citizensinformation.ie/>

[www.agriculture.gov.ie](http://www.agriculture.gov.ie)  
@agriculture\_ie



An Roinn Talmhaíochta, Bia agus Mara  
Department of Agriculture, Food and the Marine

**GALWAY COUNTY COUNCIL**  
I, Paul Sullivan, am applying to the above authority for permission for a dwellinghouse garage and wastewater treatment system in the townland of Annaghvaan Beasdaungan. This planning application may be inspected or purchased at the offices of the planning authority and a submission or observation in relation to the application may be made to the authority in writing on payment of the prescribed fee within the period of 5 weeks during office opening hours, 9:00am to 4:00pm, Monday to Friday beginning on the date of receipt by the authority of the application.

**GALWAY COUNTY COUNCIL**  
I, Donal Gallen, am applying to the above authority for permission for a wastewater treatment system to replace existing septic tank and percolation area in the townland of Drum East, Rahoon. This planning application may be inspected or purchased at the offices of the planning authority and a submission or observation in relation to the application may be made to the authority in writing on payment of the prescribed fee within the period of 5 weeks during office opening hours, 9:00am to 4:00pm, Monday to Friday beginning on the date of receipt by the authority of the application.

## McCarthy, Ann

---

**From:** McCarthy, Ann  
**Sent:** 25 September 2019 12:18  
**To:** Alab, Info  
**Cc:** OCallaghan, Grace; Foley, Gerry  
**Subject:** Ministerial decisions on aquaculture and foreshore licences in Killary Harbour  
**Attachments:** Scanned from a Xerox Multifunction Printer.pdf; Scan\_1211041.pdf

**Importance:** High

Tracking:	Recipient	Delivery	Read
	Alab, Info	Delivered: 25/09/2019 12:18	Read: 25/09/2019 12:22
	OCallaghan, Grace	Delivered: 25/09/2019 12:18	Read: 26/09/2019 12:00
	Foley, Gerry	Delivered: 25/09/2019 12:18	Read: 25/09/2019 12:30

Further to my earlier email regarding Ministerial decisions on aquaculture and foreshore licences in Killary Harbour I attach Notices of the decisions and a copy of the newspaper advertisement.

Regards,

Ann

Ann McCarthy  
Aquaculture and Foreshore Management Division Department of Agriculture Food and the  
Marine National Seafood Centre Clonakilty Co Cork  
P85 TX47

Email: [ann.mccarthy@agriculture.gov.ie](mailto:ann.mccarthy@agriculture.gov.ie)

Phone No; (023)8859537

Fax (023)8821782

## McCarthy, Ann

---

**From:** McCarthy, Ann  
**Sent:** 25 September 2019 10:11  
**To:** Alab, Info  
**Cc:** OCallaghan, Grace; Foley, Gerry  
**Subject:** Ministerial decisions on aquaculture and foreshore licences in Killary Harbour.  
**Attachments:** Scanned from a Xerox Multifunction Printer.pdf

**Importance:** High

Tracking:	Recipient	Delivery	Read
	Alab, Info	Delivered: 25/09/2019 10:11	Read: 25/09/2019 11:01
	OCallaghan, Grace	Delivered: 25/09/2019 10:11	Read: 25/09/2019 10:36
	Foley, Gerry	Delivered: 25/09/2019 10:11	Read: 25/09/2019 10:21

Please see details of Ministerial decisions on aquaculture and foreshore licences in Killary Harbour.

Regards,

Ann McCarthy  
Aquaculture and Foreshore Management Division Department of Agriculture Food and the  
Marine National Seafood Centre Clonakilty Co Cork  
P85 TX47

Email: [ann.mccarthy@agriculture.gov.ie](mailto:ann.mccarthy@agriculture.gov.ie)

Phone No; (023)8859537

Fax (023)8821782

-----Original Message-----

**From:** [ann.mccarthy@agriculture.gov.ie](mailto:ann.mccarthy@agriculture.gov.ie) [<mailto:ann.mccarthy@agriculture.gov.ie>]  
**Sent:** 25 September 2019 09:45  
**To:** McCarthy, Ann  
**Subject:** Scanned from a Xerox Multifunction Printer

Please open the attached document. It was scanned and sent to you using a Xerox Multifunction Printer.

Attachment File Type: pdf, Multi-Page

Multifunction Printer Location: Clonakilty LO, Ground Floor (Marine)  
Device Name: C-CL-GF-X7855-MFD3

For more information on Xerox products and solutions, please visit <http://www.xerox.com>

An Roinn Talmhaíochta,  
Bia agus Mara  
Department of Agriculture,  
Food and the Marine



25<sup>th</sup> September 2019.

To ALAB

File Ref: T09/511A

**NOTIFICATION OF MINISTER'S DECISION TO REFUSE TO GRANT AN  
AQUACULTURE LICENCE AND FORESHORE LICENCE.**

Dear Ms O'Hara,

I enclose a copy of the Notice of the Minister's Decision to refuse to grant an Aquaculture Licence to: Kevin & Michael Lydon, Cluggam, Maam, Co. Galway which will be advertised in the "*Connacht Tribune*" on 27<sup>th</sup> September 2019.

Yours sincerely,

Ann Mc Carthy  
Aquaculture and Foreshore Management Division  
Department of Agriculture Food and the Marine  
National Seafood Centre  
Clonakilty, Co Cork  
Email: ann.mccarthy@agriculture.gov.ie  
Tel No: 0238859537

**S.12 (3) OF THE FISHERIES (AMENDMENT) ACT, 1997(NO.23)  
INFORMATION NOTE TO APPLICANT FOR THE PURPOSE OF REGULATION 18  
OF THE AQUACULTURE (LICENCE APPLICATION) REGULATIONS 1998**

**REFERENCE NO:** T09/511

**APPLICANT:** Kevin & Michael Lydon  
Cluggam  
Maam  
Co. Galway.

**AQUACULTURE TO WHICH  
DECISION RELATES:** Cultivation of mussels using long-lines on site  
T09/511A on the foreshore in Killary Harbour, Co  
Galway.

**NATURE OF DECISION:** Refusal of Licence.

**DATE OF DECISION:** 23<sup>rd</sup> September 2019

**REASON FOR REFUSAL:**

*"Determination of Aquaculture/ Foreshore Licensing application –T09/511*

*Kevin & Michael Lydon have applied for authorisation for the cultivation of mussels using longlines on the foreshore on a 1 ha site (T09/511) in Killary Harbour, Co Galway.*

*The Minister for Agriculture, Food and the Marine has determined that it is not in the public interest to grant the Aquaculture/Foreshore Licence sought. In making his determination the Minister considered those matters which by virtue of the Fisheries (Amendment) Act 1997, and other relevant legislation, he was required to have regard. Such matters include any submissions and observations received in accordance with the statutory provisions. The following are the reasons and considerations for the Minister's determination not to grant the licence(s) sought: At current stocking levels in Killary Harbour there is significant competition for food resources which has resulted in a poor production yield of mussels and longer growing time for some producers. The Licensing of additional production sites would compound this issue further."*



25<sup>th</sup> September 2019

Ref: T09/511A

Kevin & Michael Lydon  
Cluggam  
Maam  
Co. Galway.

**FISHERIES (AMENDMENT) ACT, 1997 (NO.23)  
NOTICE OF MINISTERIAL DECISION TO REFUSE TO GRANT AN  
AQUACULTURE LICENCE AND FORESHORE LICENCE.**

Dear Sirs,

I would like to inform you that the Minister for Agriculture, Food and the Marine has refused your application for an Aquaculture Licence and Foreshore Licence, for the cultivation of mussels using long-lines on site no. T09/511A (see attached information note). I enclose a copy of the public notice of the decision which **the Department** has arranged to have published in "Connacht Tribune".

Any person aggrieved by the decision may, in accordance with Section 41 of the Fisheries (Amendment) Act 1997, appeal against it in writing to the Aquaculture Licences Appeals Board. This appeal must be lodged within one month beginning on the date of the publication of the decision.

In addition, a person may question the validity of the Foreshore Licence determination by way of an application for judicial review, under Order 84 of the Rules of the Superior Court (SI No. 15 of 1986). Practical information on the review mechanism can be obtained from the Citizens Information Board at:  
<http://www.citizensinformation.ie/>

Yours sincerely

A handwritten signature in blue ink, which appears to read "Anna McCarthy", is written over a horizontal line.

**Aquaculture and Foreshore Management Division**

**S.12 (3) OF THE FISHERIES (AMENDMENT) ACT, 1997(NO.23)  
INFORMATION NOTE TO APPLICANT FOR THE PURPOSE OF REGULATION 18  
OF THE AQUACULTURE (LICENCE APPLICATION) REGULATIONS 1998**

**REFERENCE NO:** T09/511

**APPLICANT:** Kevin & Michael Lydon  
Cluggam  
Maam  
Co. Galway.

**AQUACULTURE TO WHICH  
DECISION RELATES:** Cultivation of mussels using long-lines on site  
T09/511A on the foreshore in Killary Harbour, Co  
Galway.

**NATURE OF DECISION:** Refusal of Licence.

**DATE OF DECISION:** 23<sup>rd</sup> September 2019

**REASON FOR REFUSAL:**

*"Determination of Aquaculture/ Foreshore Licensing application –T09/511*

*Kevin & Michael Lydon have applied for authorisation for the cultivation of mussels using longlines on the foreshore on a 1 ha site (T09/511) in Killary Harbour, Co Galway.*

*The Minister for Agriculture, Food and the Marine has determined that it is **not in the public interest** to grant the Aquaculture/Foreshore Licence sought. In making his determination the Minister considered those matters which by virtue of the Fisheries (Amendment) Act 1997, and other relevant legislation, he was required to have regard. Such matters include any submissions and observations received in accordance with the statutory provisions. The following are the reasons and considerations for the Minister's determination not to grant the licence(s) sought: At current stocking levels in Killary Harbour there is significant competition for food resources which has resulted in a poor production yield of mussels and longer growing time for some producers. The Licensing of additional production sites would compound this issue further."*



**AQUACULTURE - LICENSING**  
**FISHERIES (AMENDMENT) ACT 1997**

**and**

**FORESHORE ACT 1933 as amended**

*Application Form for an Aquaculture and Foreshore Licence for  
a single specific site.*

*If a Licence is required for more than one site a separate  
application form must be completed for each site.*

**Important Note**

Section 4 of the Fisheries and Foreshore (Amendment) Act, 1998 (No. 54 of 1998) prohibits any person making an application for an Aquaculture Licence from commencing aquaculture operations until duly licensed under the Fisheries (Amendment) Act, 1997 (No. 23 of 1997), and provides that a breach of that prohibition will cause the application to fail.

A copy of an Environmental Impact Statement and Natura Impact Statement should be enclosed, if required, with all new, review and renewal applications. See Guidance Notes Section 3.

**Aquaculture & Foreshore Management Division,  
Department of Agriculture, Food and the Marine,  
National Seafood Centre,  
Clonakilty, Co. Cork  
Telephone: (023) 8859500  
Fax: (023) 8821782**




Revised 2014

**AQUACULTURE AND FORESHORE LICENCE APPLICATION FORM, for purposes of FISHERIES (AMENDMENT) ACT, 1997 and FORESHORE ACT, 1933**

**NB: The accompanying Guidance Notes should be read before completing this form.**

**Note:** Details provided in Parts 1 and 2 will be made available for public inspection. Details provided in Parts 3 and 4 and any other information supplied will not be released except as may be required by law, including the Freedom of Information Act 1997 as amended.

**USE BLOCK CAPITALS IN BLACK INK PLEASE**

<p><u>For Office Use</u></p> <p>Application Ref. No. <u>T9/511</u></p> <p>Date of Receipt (Dept. Stamp)</p> 
---

<b>Type of Applicant (tick one)</b>	
Sole Trader	<input checked="" type="checkbox"/>
Partnership	<input type="checkbox"/>
Company	<input type="checkbox"/>
Co-Operative	<input type="checkbox"/>
Other	Please specify- <input type="checkbox"/>

**PART 1: PRELIMINARY DETAILS**

<b>Applicant's Name(s)</b>	<b>KEVIN &amp; MICHAEL LYDON</b>
1.	
Address:	CLUGGAM MAAM CO. GALWAY
2.	
Address:	
3.	
Address:	
4.	
Address:	

Contact in case of enquiries (if different from above)	
Contact Name	
Organisation Name (if applicable)	
Address	

**PART 1: PRELIMINARY DETAILS**

<b>TYPE OF APPLICATION</b> – please indicate relevant type of application	
This Application Form is valid for each type of application - <i>See Guidance Note 3.1</i>	
(i) Aquaculture Licence	<input checked="" type="checkbox"/>
(ii) Trial Licence	<input type="checkbox"/>
(iii) Foreshore Licence, if Marine Based	<input type="checkbox"/>
(iv) Review of Aquaculture Licence	<input type="checkbox"/>
(v) Renewal of Aquaculture Licence	<input type="checkbox"/>

**TYPE OF AQUACULTURE**

*See Guidance Note 3.2*

Indicate the relevant type of application with a tick.

**(i) MARINE-BASED**

- |  |                                     |                          |
|--|-------------------------------------|--------------------------|
| Finfish                                  | <input type="checkbox"/>            | Go to Parts 2.1 and 2.1A |
| Shellfish <i>Subtidal</i>                | <input checked="" type="checkbox"/> | Go to Parts 2.2 and 2.2A |
| <i>Intertidal</i>                        | <input type="checkbox"/>            | Go to Parts 2.2 and 2.2A |
| Seaweed/Aquatic Plants/Aquatic Fish Food | <input type="checkbox"/>            | Go to Parts 2.3 and 2.3A |

**(ii) LAND-BASED**

- |                |                          |                   |                          |                          |
|----------------|--------------------------|-------------------|--------------------------|--------------------------|
| Finfish        | <input type="checkbox"/> | Shellfish         | <input type="checkbox"/> | Go to Parts 2.4 and 2.4A |
| Aquatic Plants | <input type="checkbox"/> | Aquatic Fish Food | <input type="checkbox"/> | Go to Parts 2.4 and 2.4A |

**(iii) TRIAL LICENCE**

- |                          |   |
|--------------------------|---|
| <input type="checkbox"/> | Go to appropriate Parts as above and to Part 2.5. |
|--------------------------|---|

## 2.2 MARINE-BASED SHELLFISH AQUACULTURE

When filling out this section refer also to 2.2A and Guidance Note 3.3 for information on Conditions and Documents required with this application type

### Proposed Site Location

- (i) Bay: KILLARY HARBOUR
- (ii) County: GALWAY
- (iii) OS Map No:11
- (iv) Co-ordinates of Site: (please specify coordinate reference system used e.g. Irish Grid (IG) or Irish Transverse Mercator (ITM) or Latitude/Longitude [in which case specify whether ETRS89 or WG84 etc.]

Kevin & Michael Lydon	
Killary Inner New Application	
Site Size = 1 Hectare	
Site Coordinates	
Irish Grid	
East	North
83500	262600
83700	262600
83700	262550
83500	262550

- (v) Size of Site (hectares): 1 HECTARE

(vi) Species (common and scientific name) and whether native or non-native species: (see Guidance Notes 3.3.1)

**BLUE MUSSEL – MYTILUS EDULIS**

(vii) Whether production will be sub-tidal or inter-tidal? **SUB-TIDAL**

(viii) Please supply details of (a) source of seed e.g. wild hatchery and location and (b) means of collection and introduction to culture. **MUSSEL SEED WILL BE NATURAL SETTLED SEED ON COLLECTION MESH AND ROPE ON LONGLINES WITHIN KILLARY HARBOUR**

NB Importation of seed into the State or movement of seed within the State requires notification to the Marine Institute as per the Fish Health Authorisation Regulations – See Guidance Notes Section 6

(ix) Method of culture (rope, trestles – intensive; bottom – extensive; other): **MUSSEL DOUBLE HEAD ROPE LONGLINES**

(x) Proposed number of lines/ropes/trestles as per site layout drawing  
**PROPOSE MUSSEL BARREL FLOATATION MAXIMUM OF 18000 LITRES PER HECTARE**

(xi) Proposed Production Tonnage:

Year 1	0	Year 2	15	Year 3	15	Year 4	15	Year 5	15
--------	---	--------	----	--------	----	--------	----	--------	----

(xii) (a) Please outline the reasons for site selection:

**SITE CLOSE TO OUR EXISTING SITES T09/184B AND T09/308B IN KILLARY HARBOUR**

---

(b) If using trestles please outline the physical characteristics of the site which make it suitable for using trestles

N/A

(xiii) Is it intended that the product is for direct human consumption or half grown? Please specify

FULL GROWN AT END OF GROWING CYCLE FOR DIRECT HUMAN CONSUMPTION

(xiv) How will the visual impact issues of the flotation devices for the proposed application be addressed?

ALL FLOATATION BARRELS WILL BE GREY IN COLOUR.

(xv) Is the site located in Designated Shellfish Waters Area? (Refer to Guidance Note 3.3.2)

Yes  No

If yes give details.

KILLARY HARBOUR MAP NO. XI

If no outline the reasons why you believe the site suitable for the proposed aquaculture, notwithstanding its location outside Designated Shellfish Waters Area?

---

---

(xvi) Has the area been classified under Food Safety Legislation? (For Bivalve Molluscs) What is the current classification of the area for the proposed species applied for?

CURRENT BI-VALVE CLASSIFICATION 2015 = 'B' CLASSIFICATION

(xvii) Is the site located in/adjacent to a sensitive area e.g. SPA (Special Protection Area) or SAC (Special Area of Conservation) i.e. a Natura 2000 site? (Refer to Guidance Note 3.3.1- Natura 2000 sites)

ADJACENT TO 3 SAC SITES – NUMBERS 002031, 001932 AND 002008

(xviii) Are there known sources of pollution in the vicinity e.g. sewage outfall? Yes / No

If yes please give full details. NO. THERE IS A WWTP AT NEARBY LEENANE VILLAGE

---

(xix) Methods used to harvest the shellfish and details of any subsequent processing of shellfish: THE ROPE MUSSELS WILL BE HARVESTED BY MUSSEL EQUIPMENT ONBOARD OUR MUSSEL BOAT. MUSSELS WILL BE PACKED INTO EITHER 1 TONNE BAGS OR 20KG BAGS ONBOARD VESSEL BEFORE BRINGING THEM ASHORE TO BUNDORRAGHA PIER FOR TRANSPORT TO PROCESSING FACTORY OR FOR FRESH MARKET.

(xx) Describe any proposed purification facilities to be used: MUSSELS WILL BE PURIFIED WHEN REQUIRED BY PROCESSOR/BUYERS EXPORTERS FOR FRESH MARKET

(xxi) What are the main predators of the species to be cultivated?

NO PREDATORS AT PRESENT ON OUR SITES IN KILLARY

(xxii) Describe the method(s) which will be used to control them

See Part 2.2A for details of documentation to be included with this application type

### **2.2A DOCUMENTATION REQUIRED FOR MARINE-BASED SHELLFISH AQUACULTURE**

(to be included separately with a Licence Application for a new site or for a renewal or review of an existing Licence)

1. **An appropriate Ordnance Survey Map (recommendation is a map to the Scale of 1:10,000/1:10,560, i.e. equivalent to a six inch map).** Note: The proposed access route to the site from the public road across tidal foreshore must also be shown on the map.
2. **Scale drawing of the structures to be used and the layout of the farm.**  
The proposed site drawings must illustrate all site structures above and below the water including mooring blocks. (recommended scales normally 1:100 for structures and 1:200 for layout ) (See Guidance Note 3.3.2)
3. **The prescribed application fee (See Guidance Note Section 4)**
4. **If the applicant is a limited Company within the meaning of the Companies Act 1963, as amended, the Certificate of Incorporation and Memorandum and Articles of Association**
5. **If the applicant is a Co-operative, the Certificate of Incorporation and Rules of the Co-operative Society**
6. **Environmental Impact Statement (if required) in certain cases- See Guidance Notes Section 3.3.1**
7. **Alien Species dossier ( where required) – See Guidance Notes Section 3.3.1**

**NOW COMPLETE PARTS 2.6, 3, 4 AND 5 PLEASE**

**2.6 Employment, Qualifications, Experience, etc  
TO BE FILLED IN BY ALL AQUACULTURE APPLICANTS**

(i) Please provide details of experience/qualifications of the applicant and any key personnel which are relevant to the aquaculture now proposed:

BOTH KEVIN AND MICHAEL LYDON HAVE BEEN INVOLDED IN MUSSEL FARMING SINCE 1984. THEY HAVE ATTENDED NUMEROUS SHELLFISH COURSES, SEMINARS AND WORKSHOPS OVER THE YEARS. THEY BOTH HOLD THE BIM SAFETRY TRAINING CARD, HAVE DIVING TRAINING CERTS PART IV AND A VHF RADIO TRAINING AND LICENCE.

- (ii) If a new application please provide details of projected employment creation during first four years of the proposed aquaculture project:  
 (iii) In the case of a renewal please provide current and future details:

THIS APPLICATION ALONG WITH OUR OTHER APPLICATIONS AND EXISTING LICENCES WILL ENABLE US TO EMPLOY IN THE FUTURE 1 EXTRA FULL-TIME AND 2 PART-TIME PERSONS .

**FULLTIME JOBS ALONG WITH OUR OTHER KILLARY LICENSED SITES**

Year 1:	2	Year 2:	2	Year 3:	2	Year 4:	3
---------	---	---------	---	---------	---	---------	---

**PART TIME JOBS**

Year 1:	0	Year 2:	1	Year 3:	2	Year 4:	2
---------	---	---------	---	---------	---	---------	---

**CONFIDENTIAL**

**PART 3: APPLICANT DETAILS**

**PART 3 A. INDIVIDUAL(S)/SOLE TRADER(S)**

(If necessary continue with extra page(s))

1. Name: KEVIN LYDON

Personal Public Service No. [REDACTED]

Date of Birth: [REDACTED]

Telephone No. [REDACTED]

Mobile No. [REDACTED]

E-mail Address: [REDACTED]

2. Name: MICHAEL LYDON

Personal Public Service No. [REDACTED]

Date of Birth: [REDACTED]

Telephone No.

Mobile No. [REDACTED]

E-mail Address \_\_\_\_\_

3. Name: \_\_\_\_\_

Personal Public Service No. \_\_\_\_\_

Date of Birth: \_\_\_\_\_

Telephone No. \_\_\_\_\_

Mobile No. \_\_\_\_\_

E-mail Address \_\_\_\_\_

4. Name: \_\_\_\_\_

Personal Public Service No. \_\_\_\_\_

Date of Birth: \_\_\_\_\_

Telephone No. \_\_\_\_\_

Mobile No. \_\_\_\_\_

E-mail Address \_\_\_\_\_



## PART 5: APPLICATION DOCUMENTATION

The following documents are enclosed with this application:

**NB: Refer to Guidance Note Section 3.3 – Guidance on Application Documentation**

No.	DOCUMENTATION	YES	NO	N/A
1	An appropriate Ordnance Survey Map (recommendation is a map to the scale of 1:10,000/10:10,560, i.e., equivalent to a six inch map)	X		
2	Scale drawing of the structures to be used and the layout of the farm (recommended scales normally 1:100 for structures and 1:200 for layout )	X		
3	The prescribed application fee	X		
4	Environmental Impact Statement (EIS), if required			X
4a	Natura Impact Statement (NIS), if required			X
5	Water Quality Analysis Report, if appropriate			X
6	Decision of Planning Authority under the Planning Acts, if required			X
7	Copy of Licence under Section 4 of the Local Government (Water Pollution) Act, 1977 – Effluent Discharge, if required			X
8	If the applicant is a limited Company within the meaning of the Companies Act 1963, as amended, a copy of the Certificate of Incorporation and Memorandum and Articles of Association.			X
9	If the applicant is a Co-operative, a copy of the Certificate of Incorporation and Rules of the Co-operative Society			X
10	Integrated Pest Management Plan, if required			X
11	Alien Species documentation, if required.			X

**PART 5: DECLARATION AND SIGNING**

**NB: Refer to Guidance Note Section 3.5 and Section 4 - Guidance on Declaration and Signing and Annual Aquaculture and Foreshore Licence Fees**

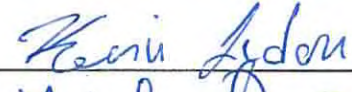
If this is a renewal/review have you met all licence conditions of the existing aquaculture licence? If applicable, explain why you have not complied with all conditions:

N/A

I/We hereby declare the information provided in Parts 1, 2, 3 and 4 above to be true to the best of my/our knowledge. I/We enclose an application fee\* of €95.23 with this application.

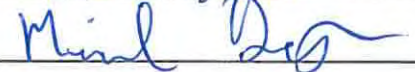
Signature(s) of Applicant(s):

KEVIN LYDON

  
\_\_\_\_\_

(Please state capacity of persons signing on behalf of a Company/Co-op)

MICHEAL LYDON

  
\_\_\_\_\_

Date: 27/11/2015

**NB All persons named on this licence application must sign and date this application form. Only the existing licence holder(s) can apply for the renewal/review of an Aquaculture Licence.**

\*Preferred method of payment is by cheque or bank draft. The fee should be made payable to the Department of Agriculture, Food and the Marine.

**Refer to Guidance Note Section 4 - Guidance on Aquaculture and Foreshore Licence Fees**

The application form should be forwarded, with the required documents and application fee, to:

**Aquaculture Licensing  
Aquaculture & Foreshore Management Division  
Department of Agriculture, Food and the Marine  
National Seafood Centre  
Clonakilty  
Co. Cork**

**1 NO. SITE AT KILLARY HARBOUR CO.GALWAY**

**Co-ordinates & Area**

**Site T09/511A (1 Ha)**

The area seaward of the high water mark and enclosed by a line drawn from Irish National Grid Reference point

083500, 262600 to Irish National Grid Reference point

083700, 262600 to Irish National Grid Reference point

083700, 262550 to Irish National Grid Reference point

083500, 262550 to the first mentioned point.

83000

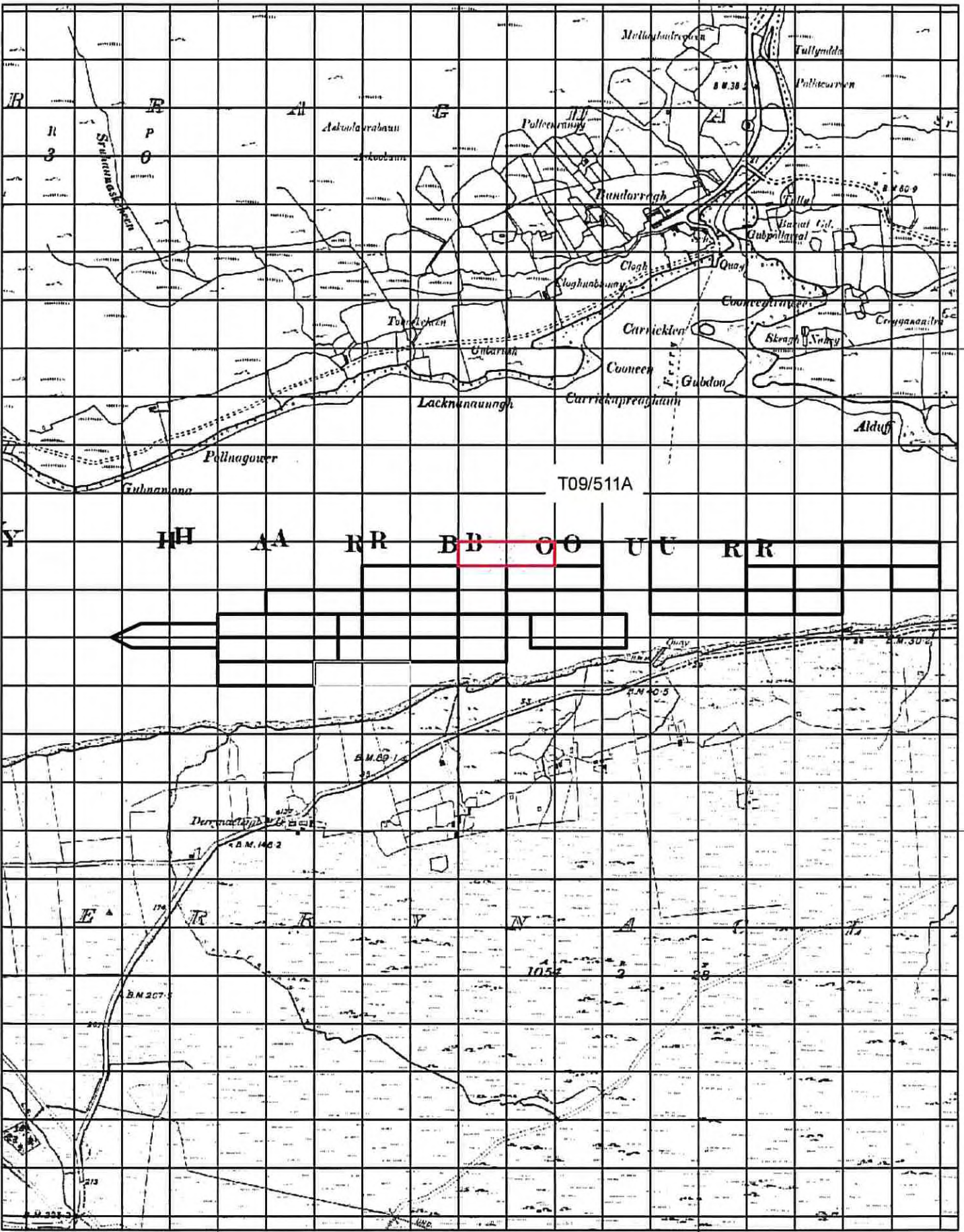
84000

263000

263000

262000

262000



T09/511A

83000

84000

**Aqua Culture Sites**

- <all other values>
- Site\_Status**
- Application
- Lapsed
- Licensed
- Refused
- Renewal
- Revoked
- Surrendered
- Withdrawn
- Existing\_Shellfish\_Areas
- Shellfish Designation areas
- 100 Meter Reference Grid

1:10,560

Sites highlighted in red denotes Application

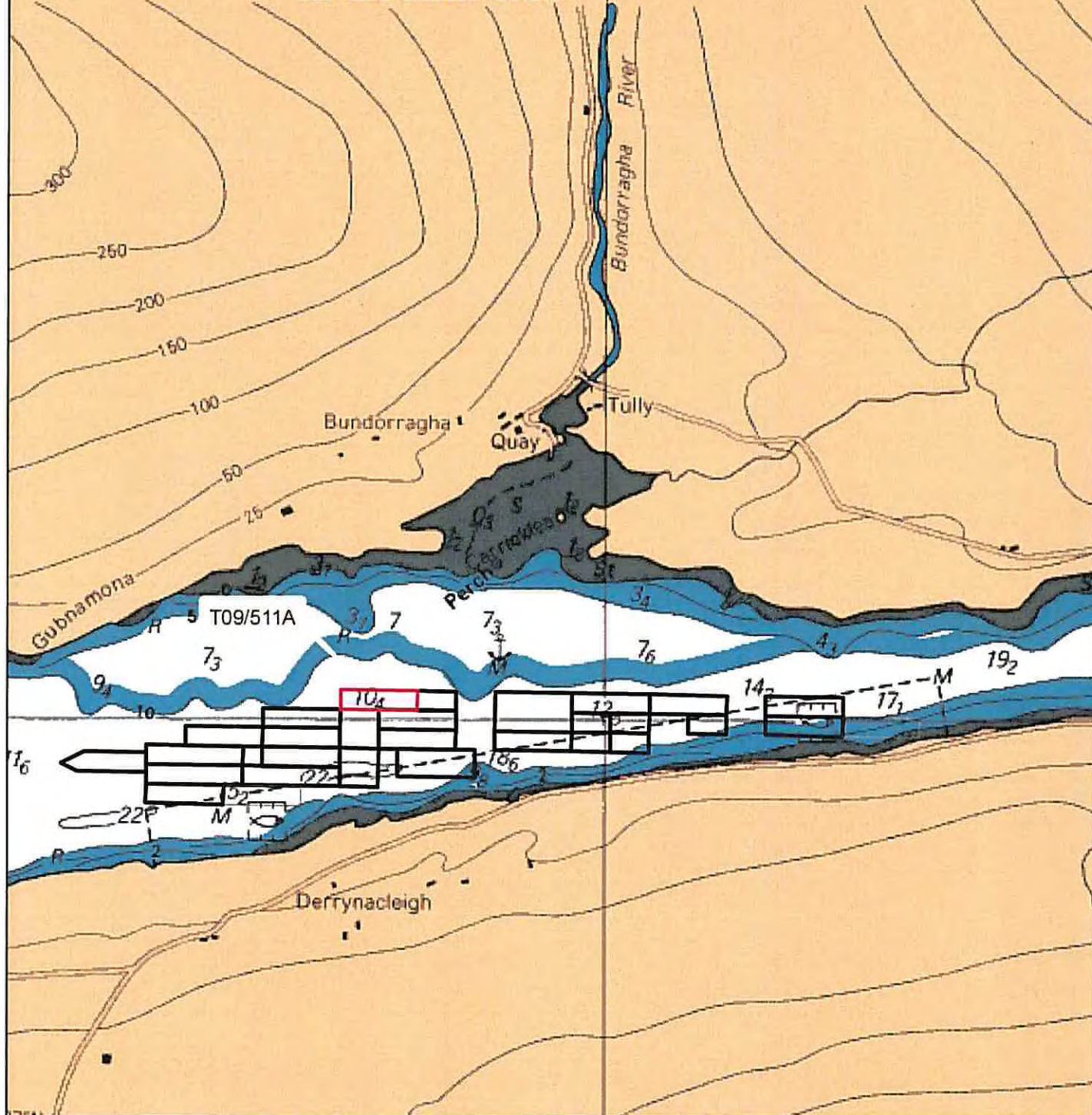
Ordnance Survey Ireland Licence No. EN 0076413  
© Ordnance Survey Ireland/Government of Ireland



Department of  
**Agriculture,  
Food and the Marine**  
An Roinn  
**Talmhaíochta,  
Bia agus Mara**

# Continuation of KILLARY HARBOUR

on the same scale



- Aqua Culture Sites**  
<all other values>
- Site\_Status**
- Application
  - Lapsed
  - Licensed
  - Refused
  - Renewal
  - Revoked
  - Surrendered
  - Withdrawn

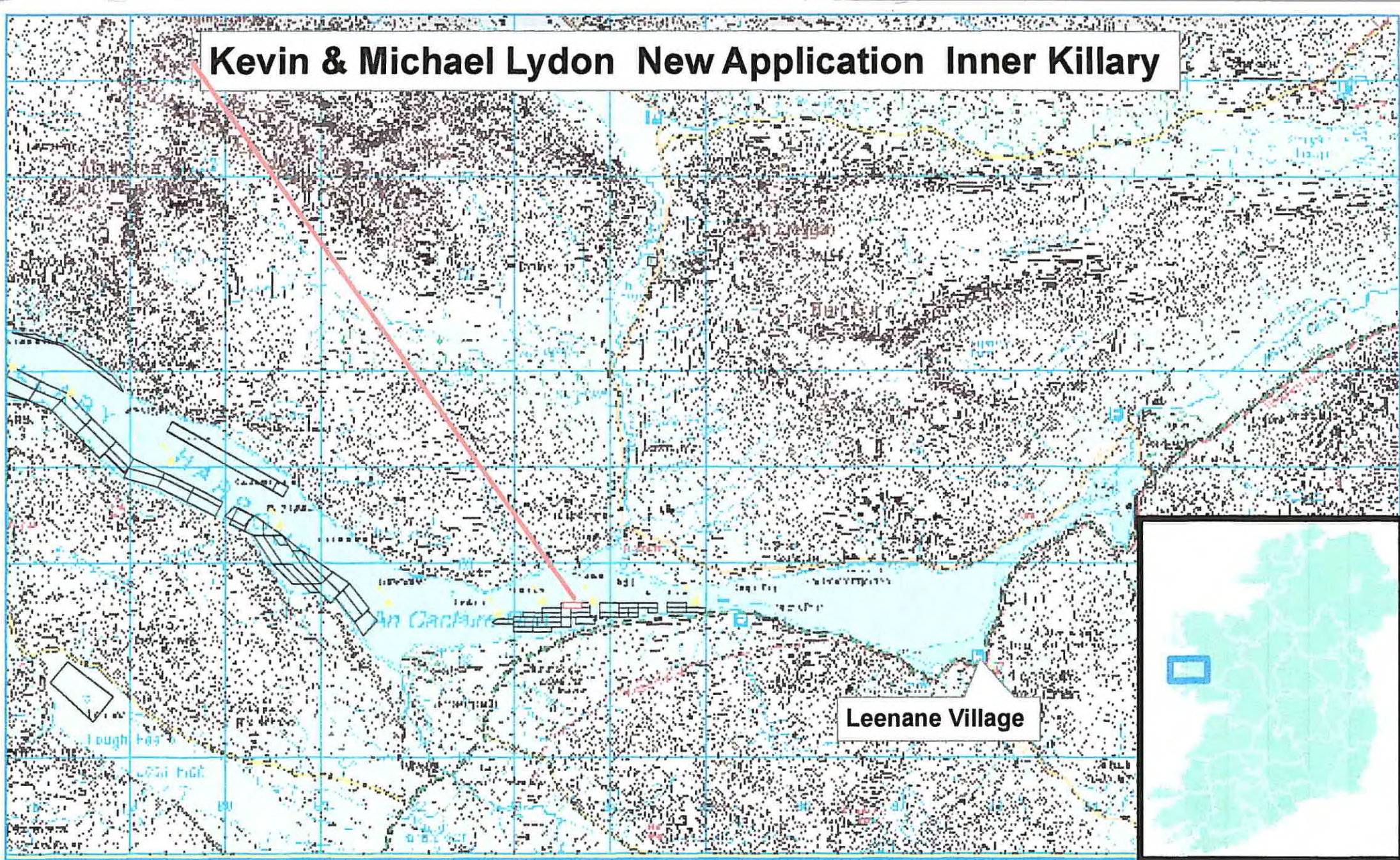
1:15,000

Sites highlighted in red denotes Application

Part of Admiralty Chart No 2706-1  
Not to be used for Navigation



# Kevin & Michael Lydon New Application Inner Killary

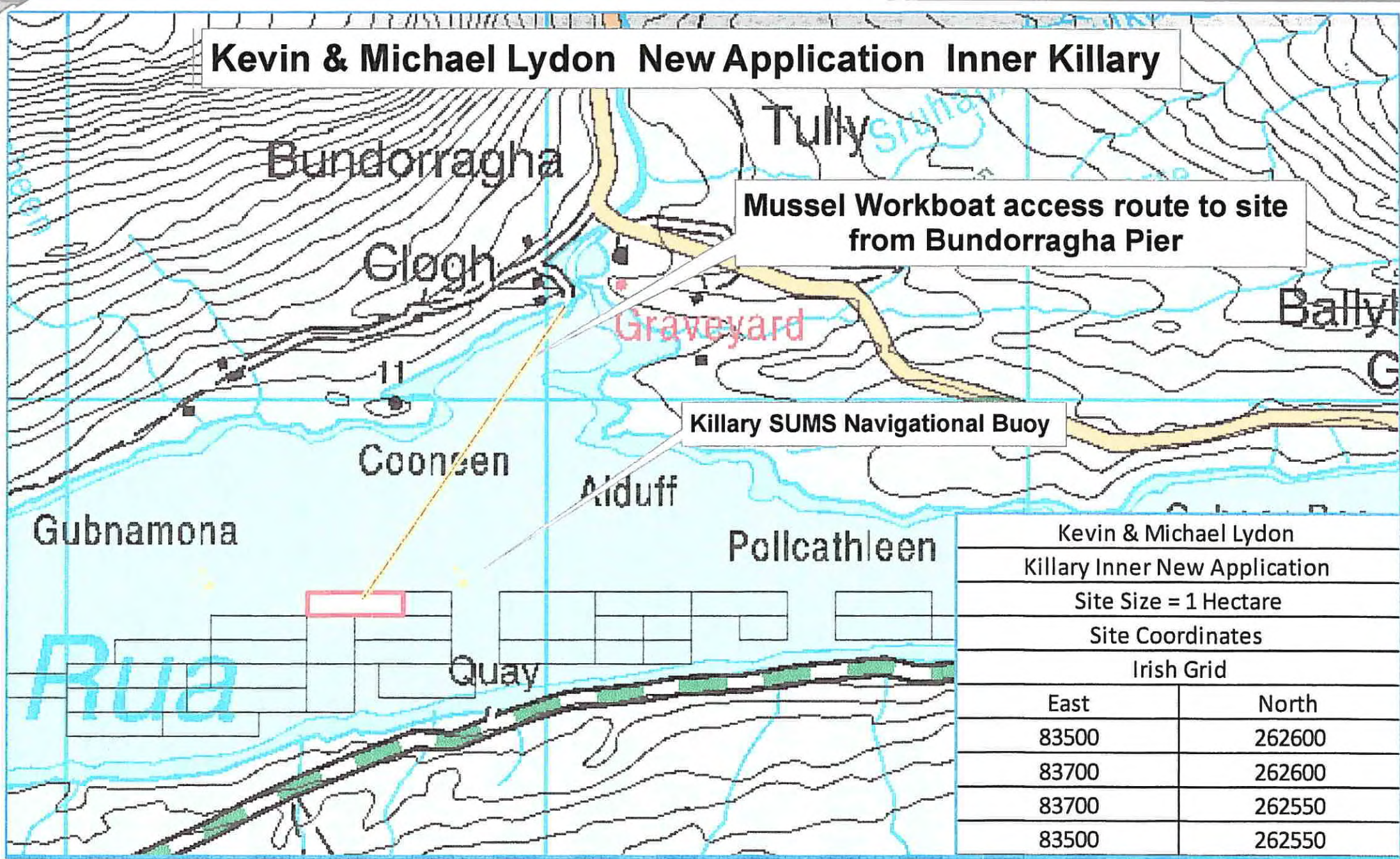


0 1,250 2,500 5,000 Meters

1:50,000

22.09.15

# Kevin & Michael Lydon New Application Inner Killary

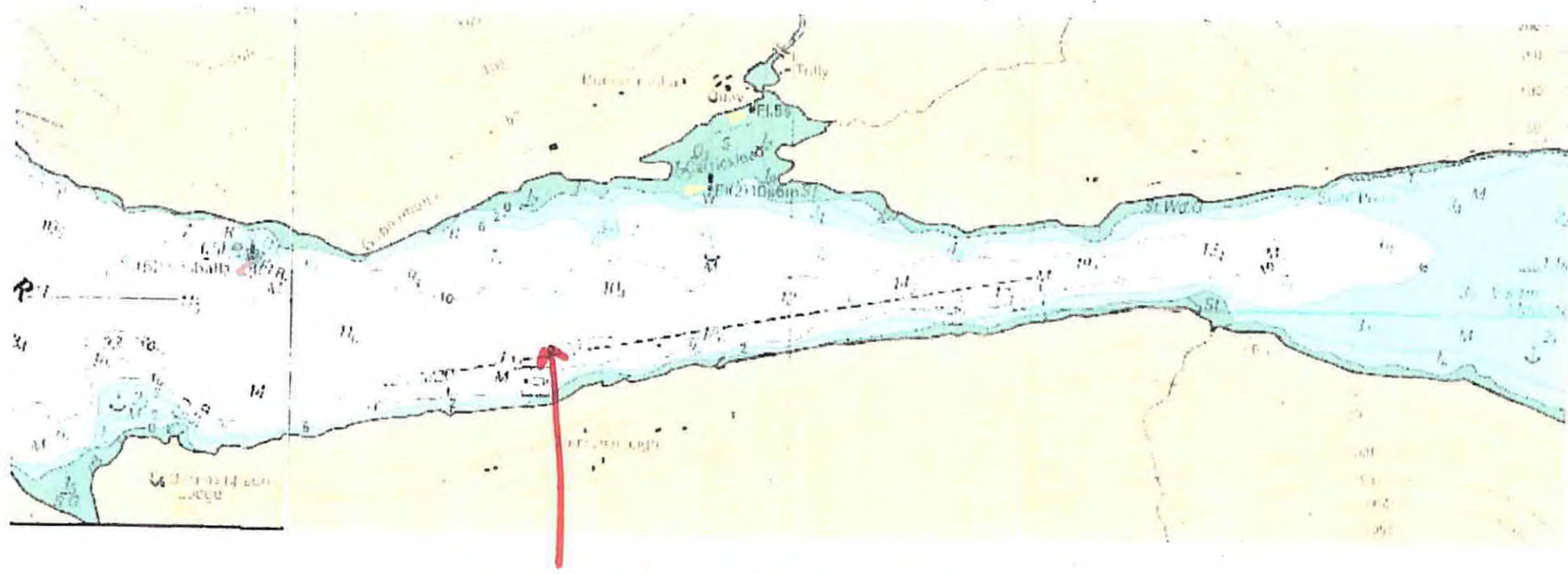


Kevin & Michael Lydon	
Killary Inner New Application	
Site Size = 1 Hectare	
Site Coordinates	
Irish Grid	
East	North
83500	262600
83700	262600
83700	262550
83500	262550

0 250 500 1,000 Meters

1:10,000

# Killary Admiralty Chart 2706 - Inner Killary



Approx. location of  
Proposed SITE M+K Lydon

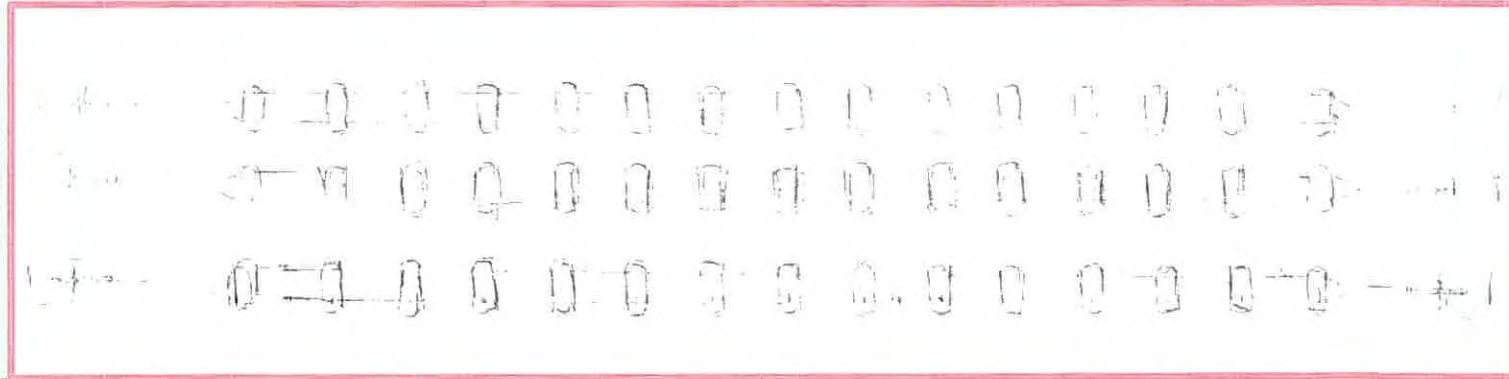


# Kevin & Michael Lydon New Application Inner Killary Site Layout



200 metres

50 metres



T09/296B

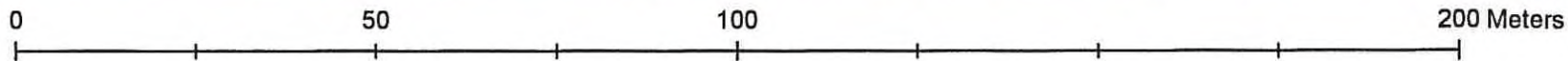
T09/363

T09/308B

T09/372B

T09/341B

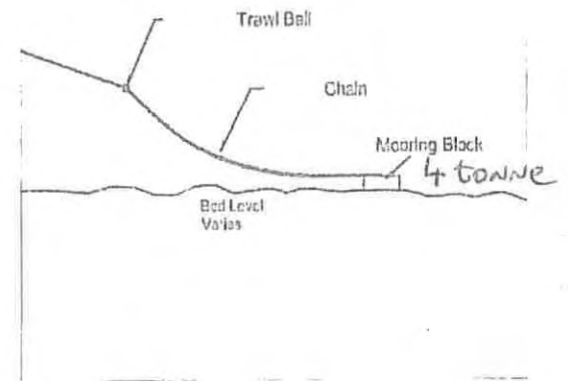
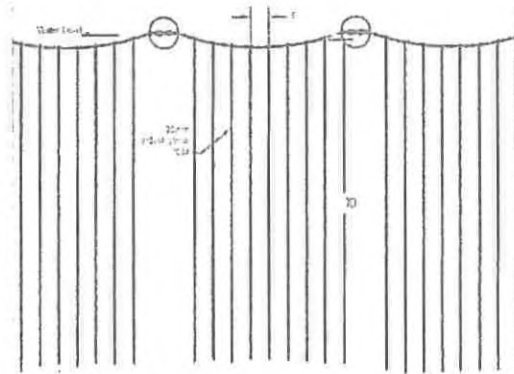
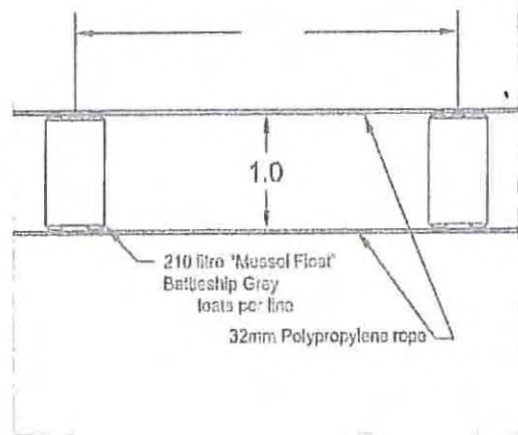
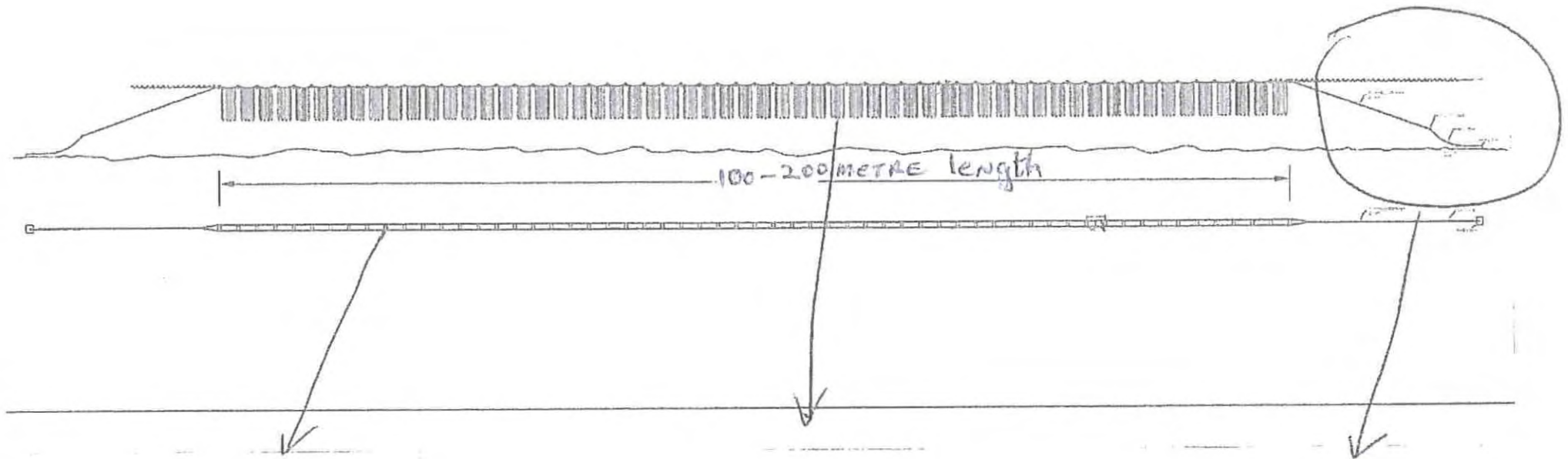
Kevin & Michael Lydon	
Killary Inner New Application	
Site Size = 1 Hectare	
Site Coordinates	
Irish Grid	
East	North
83500	262600
83700	262600
83700	262550
83500	262550



1:1,000

22.09.15

# Rope Mussel Longline Structure Drawings



# Rope Mussel Longline Cultivation



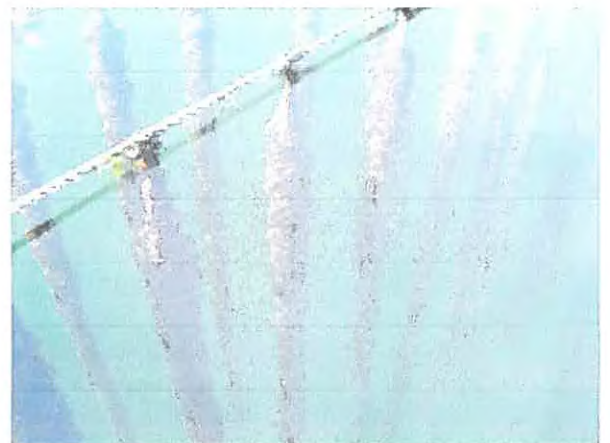
Double headed Rope Mussel Longline with grey Barrel Floatation



NZ Continuous Mussel Longline system - currently being introduced into our Killary Harbour sites.



SUMS Navigational Buoy Killary



Mussel Longline Droppers

Recommendation to refuse to grant an Aquaculture Licence and a Foreshore Licence for 1 site  
(T09/511)

### **Action Required**

Ministerial determination on Aquaculture/Foreshore Licensing Application (T09/511)

### **Executive Summary**

The Minister's determination is requested in relation to an application for an Aquaculture Licence from Kevin & Michael Lydon, Cluggam, Maam, Co. Galway. The application is for the cultivation of mussels using longlines on a site (T09/511), totalling 1 ha, on the foreshore in Killary Harbour, Co Galway. A submission in respect of the application for a Foreshore Licence is also set out for the Minister's consideration.

It is recommended that the Minister determines that the application for Aquaculture and Foreshore Licences **not be granted** for the reasons set out in the submission below.

Killary Harbour, at present, has major issues with existing sites due to overstocking, lack of growth and seed availability. Additional licensed areas would not improve this situation.

**Note: Tabs may contain additional information which is subject to redaction if transmitted to third parties.**

### **DECISION SOUGHT**

**Recommendation to refuse to grant an Aquaculture Licence and a Foreshore Licence for 1 site  
(T09/511)**

The Minister's determination is requested please in relation to an application for an Aquaculture Licence from Kevin & Michael Lydon, Cluggam, Maam, Co. Galway, for a site in Killary Harbour, Co Galway.

Also attached is a submission in respect of the accompanying Foreshore Licence, for the Minister's consideration.

## **BACKGROUND**

Marine aquaculture operations require separate Aquaculture and Foreshore Licences and Ministerial approval is required in respect of this submission (Aquaculture Submission) and submission underneath (Foreshore Submission), which refer to the same site.

The Aquaculture Licence defines the activity that is permitted on a particular site and the Foreshore Licence allows for the occupation of that particular area of foreshore. The continuing validity of each licence is contingent on the other licence remaining in force.

## **APPLICATION FOR AN AQUACULTURE LICENCE**

An application for an Aquaculture Licence has been received from the applicant referred to above (in conjunction with an application for a Foreshore Licence), for the cultivation of mussels using longlines on a site (T09/511), totalling 1 ha, in Killary Harbour, Co. Galway (see **Tab A**).

## **LEGISLATION**

Section 7 of the Fisheries (Amendment) Act 1997 provides that the licensing authority (i.e. Minister, delegated officer or, on appeal, the Aquaculture Licence Appeals Board) may, if satisfied that it is in the public interest to do so, license a person to engage in aquaculture.

Article 6 (3) of the Habitats Directive provides that *“Any plan or project not directly connected with or necessary to the management of the site but likely to have a significant effect thereon ... shall be subject to appropriate assessment of its implications for the site in view of the site’s conservation objectives ... the competent national authorities shall agree to the plan or project only after having ascertained that it will not adversely affect the integrity of the site concerned ...”*

## **CONSULTATION AND PUBLIC COMMENT**

The application was sent to the Department’s technical experts, statutory consultees and was also publicly advertised in a composite public notice covering both aquaculture and foreshore elements.

### **Technical Consultation (See **Tab B**)**

Marine Engineering Division (MED): The proposed site is located on the south shore of Inner Killary Harbour, Co. Galway. Killary Harbour is largely sheltered from wind and wave action making it an ideal area for aquaculture. This aquaculture site has been in existence for 20 years, which indicates that the hydrodynamic regime is suitable for this type of aquaculture. As the mussel production sites

in Killary Harbour are not located within a Natura 2000 site there will be no direct impacts from this operation.

However, there is overstocking, lack of growth and seed availability issues within Killary Harbour. This site, if licensed, will significantly impact on production in the area. MED also stated that this site is currently not in use and leaving this area fallow will allow for improved water flow for the existing surrounding sites as per the UISCE report recommendations (See **Tab C**).

For the reasons outlined above, Marine Engineering Division does not recommend the licensing of this site.

Sea Fisheries Protection Authority: Stated no objections to this application.

Marine Survey Office: As a technical consultee to the Department, the Marine Survey Office was asked to provide observations but did not submit a response.

#### **Statutory Consultation (See Tab D)**

Regulation 10 of the Aquaculture (Licence Application) Regulations, 1998 requires certain statutory bodies to be notified of an Aquaculture Licence application.

Comments were received from the following statutory bodies:

Marine Institute: Noted that the site is located in a designated Shellfish Growing Waters Area. Following considerations implicit to Sections 61 (e and f) of the Fisheries (Amendment) Act 1997, the Marine Institute is of the view that there will be no significant impacts on the marine environment and that the quality status of the area will not be adversely impacted.

Site T09/511 is not located within a designated Natura 2000 site, and as set out in the AA Screening Report for Killary Harbour, the Marine Institute is of the view that significant impacts on any adjacent Natura 2000 are not likely (See **Tab E**).

The Marine Institute however is of the view that at current stocking levels in Killary Harbour there is significant competition for food within the bay, which has resulted in a poor production yield of mussels, a lower product quality and longer growing time for some producers. The Licensing of

additional production sites would compound this issue further. On this basis, the Marine Institute recommends that an aquaculture licence for the production of mussels at this site should not be granted.

Commissioner of Irish Lights: Stated no objection to this licence application from a navigational viewpoint.

Inland Fisheries Ireland (IFI): IFI previously expressed serious concern about the excessive number of licences issued in Killary Harbour for the cultivation of mussels and the concern of IFI has been reflected in the decreased growth rates achieved in the bay since the substantial increase in the number of licences in the bay.

Consideration must be given to the production capacity of the bay, which by virtue of the fact that these farms rely on natural production for growth, is very limited. Mussels are filter feeders and fed exclusively on the planktonic foodstuffs in the bay. This is dictated by the natural production capacity of the bay. Regardless of the number of mussels alive in the bay only a specific biomass can be grown annually.

IFI also stated that Killary Harbour has suffered from algal blooms annually that render the shellfish in the bay toxic if consumed by humans. This is a further reason for the limiting of the producers and the capping of production of Mussels in the bay.

They concluded that on the basis of existing scientific data the issuing of any further longline shellfish licences in Killary Harbour would be both scientifically unsound and economically unwise.

Bord Iascaigh Mhara: Stated that they have no objections from an aquaculture or inshore fisheries point of view.

Statutory Consultation requests were also issued to the Department of Housing, Planning and Local Government, Department of Culture, Heritage and the Gaeltacht, An Taisce, Udaras na Gaelige, Irish Water, Galway County Council and Failte Ireland, however no response was received from these agencies.

## **Public Consultation**

The application was publicly advertised using a composite public notice covering both the aquaculture and foreshore elements, in the “Connacht Tribune” on 5<sup>th</sup> April 2019. The application and supporting documentation were available for inspection at Letterfrack and Clifden Garda Stations for a period of 4 weeks from the date of publication of the notice in the newspaper.

**No objections** were received arising from the public consultation process.

### **Response to Statutory/Public Consultation**

In accordance with the applicable legislation copies of the observations/objections received by AFMD during the statutory and public consultation process were forwarded to the applicant for comment. Kevin & Michael Lydon made the following comments in response:

*“IFI have objected to the granting of all three licences (T09/509, T09/510 & T09/511) and the Marine Institute to T09/510 and T09/511 on the grounds of overstocking in Killary Harbour. All of these sites are in the inner bay where there are no growth problems. Whilst they are new licences, these sites were previously licensed along with all current licences, but still there was no major growth issues in the inner bay as can be confirmed by the Carrying Capacity Report 2010.*

*With regards to the Marine Institute concerns over the introduction of invasive non-native species, in our thirty-five years of mussel farming in Killary Harbour there has always been sufficient spat collection naturally in the bay for production purposes. Spat quantities do fluctuate from season to season and in the most unlikely event of a total collapse we would not like to see any seed be introduced to Killary Harbour due to the possible detrimental damage it could cause.*

*With regards to IFI concerns over algal blooms, Killary Harbour usually has very low levels of blooms and in some years, none at all. There is a very robust monitoring programme in place conducted by the Marine Institute to alert producers if toxic blooms are imminent, This allows the producers to take appropriate action to safeguard human health.*

*With regards to the Commissioners of Irish Lights, we are happy to comply with their recommendations.*

*Finally, we are glad to note that BIM, technical advisors to DAFM, have no objections to the granting of the licence.”*



The applicant's response to the Statutory Consultees observations was forwarded to the Marine Institute and the Department's Marine Engineering Division for comment. The Marine Institute replied as follows:

*"We have considered the responses of the applicants to the comments made by the Statutory Consultees. We remain of the view that our comments in relation to the stocking density / carrying capacity of the system as they relate to new applications are valid and we have no additional comments.*

*IFI is correct in relation to occurrence of marine biotoxins in mussels in Killary which can occasionally make them unsafe for human consumption. Notwithstanding this, however, you will be aware that the Marine Institute has in place a comprehensive, ongoing national marine biotoxin monitoring programme to detect the presence of these toxins in shellfish in all shellfish production area, including Killary harbour. Details of this programme are available at <https://www.marine.ie/Home/site-area/areas-activity/seafood-safety/shellfish-biotoxins>*

*When biotoxins are detected in shellfish at concentrations above the regulatory limit set out in EU Regulation 853/2004, the harvesting and placing on the market of the affected shellfish is prohibited and is only permitted when the concentration of biotoxins falls below the regulatory limit for at least 2 consecutive weeks. In this way the risk of placing unsafe product on the market is minimised. The results of all biotoxin testing in shellfish as part of this monitoring programme are published on the Marine Institute Web site at <http://webapps.marine.ie/HABs/>*

*On the basis of the above, it is the Marine Institute view that the occurrence of biotoxins in shellfish in Killary Harbour, or any other licenced production area, does not of itself make the area unsuitable for shellfish production or represents sufficient grounds for limiting the production."*

#### **CRITERIA IN MAKING LICENSING DECISIONS**

The licensing authority, in considering an application, is required by statute to take account, as appropriate, of the following points and also be satisfied that it is in the public interest to licence a person to engage in aquaculture:

a) the suitability of the place or waters

*The application area is located on the south shore of middle Killary Harbour, Co. Galway. Aquaculture activity in the harbour has been in existence for many years which indicates that the hydrodynamic*

*regime is suitable for this type of aquaculture. However, Killary Harbour has issues with existing sites relating to stocking levels, lack of growth and seed availability.*

b) other beneficial uses of the waters concerned

*Public access to recreational and other activities can be accommodated by this project.*

c) the particular statutory status of the waters

(i) Natura 2000

This site is not located within a designated Natura 2000 site and, as set out in the AA Screening Report for Killary Harbour, significant impacts on any adjacent Natura 2000 are not likely.

(ii) Shellfish Waters

*The site is located in Killary Harbour Shellfish Designated Waters. Mussels in Killary Harbour currently have a "B" classification (under Annex II of EU Regulation 854/2004).*

d) the likely effects on the economy of the area

*Aquaculture has the potential to provide a range of benefits to the local community.*

e) the likely ecological effects on wild fisheries, natural habitats, flora and fauna

*The potential ecological impacts of aquaculture activities on natural habitats, flora and fauna are addressed at (c) (i) above.*

f) the effect on the environment generally

*The aquaculture in Killary Harbour has been in place for the last 30 years and has become embedded in the landscape. The types of structures adhere to the best practices outlined in the Guidelines for Landscape and Visual Impact Assessment of Marine Aquaculture, 2001. No chemicals or hazardous substances will be used during the production process. The Minister is obliged pursuant to Regulation 5 (2) of Licence Application Regulations to consider on a case by case basis whether the proposed aquaculture is likely to have a significant effect on the environment.*

## **RECOMMENDATION**

It is recommended that the Minister:

**refuses the granting** of an the Aquaculture Licence to Kevin & Michael Lydon, Cluggam, Maam, Co. Galway. The reason for the recommendation to refuse the granting of the application is as follows:

At current stocking levels in Killary Harbour there is significant competition for food resources which has resulted in a poor production yield of mussels, a lower product quality and longer growing time for some producers. The Licensing of additional production sites would compound this issue further.

## **REASONS FOR DECISION**

The Minister for Agriculture, Food and the Marine is required to give public notice of both the licensing determination and the reasons for it. To accommodate this it is proposed to publish the following determination on the Department's website in relation to this site, subject to the Minister approving the above recommendation:

### *"Determination of Aquaculture/ Foreshore Licensing application –T09/511*

*Kevin & Michael Lydon have applied for authorisation for the cultivation of mussels using longlines on the foreshore on a 1 ha site (T09/511) in Killary Harbour, Co Galway.*

*The Minister for Agriculture, Food and the Marine has determined that it is **not in the public interest** to grant the Aquaculture/Foreshore Licence sought. In making his determination the Minister considered those matters which by virtue of the Fisheries (Amendment) Act 1997, and other relevant legislation, he was required to have regard. Such matters include any submissions and observations received in accordance with the statutory provisions. The following are the reasons and considerations for the Minister's determination not to grant the licence(s) sought: At current stocking levels in Killary Harbour there is significant competition for food resources which has resulted in a poor production yield of mussels and longer growing time for some producers. The Licensing of additional production sites would compound this issue further."*

Submitted for approval, please.

Deirdre O'Flynn

Aquaculture and Foreshore Management Division

## **Recommendation to refuse to grant a Foreshore Licence application (T09/511)**

## **DECISION SOUGHT**

The Minister's determination is requested please in relation to an application for a Foreshore Licence from Kevin & Michael Lydon, Cluggam, Maam, Co. Galway for a site in Killary Harbour, Co. Galway, on which it is proposed to conduct aquaculture.

## **BACKGROUND**

Marine aquaculture operations require separate Aquaculture and Foreshore Licences and Ministerial approval is required in respect of this submission (Foreshore Submission) and submission above (Aquaculture Submission), which refer to the same site.

The Foreshore Licence allows for the occupation of the particular area of foreshore while the Aquaculture Licence defines the activity that is permitted in this area. The continuing validity of each licence is contingent on the other licence remaining in force.

## **APPLICATION FOR A FORESHORE LICENCE**

An application for a Foreshore Licence has been received from the applicant referred to above (in conjunction with an Aquaculture Licence application), relating to the occupation of the foreshore at a site (T09/511 – 1 ha) in Killary Harbour (see **Tab A**).

## **LEGISLATION**

Section 3 of the Foreshore Act, 1933 gives power to the Minister to license the use of foreshore, if he is of the opinion that it is in the public interest to do so.

## **CONSULTATION AND PUBLIC COMMENT**

The application was sent to the Department's technical experts, and was also publicly advertised in a composite public notice covering both aquaculture and foreshore elements.

This application was also sent to the Department of Housing, Planning and Local Government (DHPLG) in accordance with subsection (1B) of Section 3 of the Foreshore Act, 1933, which requires consultation between the Minister for Agriculture, Food and the Marine and the Minister for Housing, Planning and Local Government. Whilst aquaculture legislation requires certain statutory bodies to be notified of an aquaculture application, no other statutory bodies are prescribed consultees under Fisheries related foreshore legislation.

Department of Housing, Planning and Local Government: There were no comments received from a water quality or foreshore perspective.

### **Technical Consultation**

Marine Engineering Division (MED): The proposed site is located on the south shore of Inner Killary Harbour, Co. Galway. Killary Harbour is largely sheltered from wind and wave action making it an ideal area for aquaculture. This aquaculture site has been in existence for 20 years, which indicates that the hydrodynamic regime is suitable for this type of aquaculture. As the mussel production sites in Killary Harbour are not located within a Natura 2000 site there will be no direct impacts from this operation.

However, there is overstocking, lack of growth and seed availability issues within Killary Harbour. This site, if licensed, will significantly impact on production in the area. MED also stated that this site is currently not in use and leaving this area fallow will allow for improved water flow for the existing surrounding sites as per the UISCE report recommendations (See **Tab C**).

For the reasons outlined above, Marine Engineering Division does not recommend the licensing of this site.

Sea Fisheries Protection Authority: Stated no objections to this application.

Marine Survey Office: As a technical consultee to the Department, the Marine Survey Office was asked to provide observations but did not submit a response.

### **Public Consultation**

The application was publicly advertised using a composite public notice covering both the aquaculture and foreshore elements, in the "Connacht Tribune" on 5<sup>th</sup> April 2019. The application and supporting documentation were available for inspection at Letterfrack and Clifden Garda Stations for a period of 4 weeks from the date of publication of the notice in the newspaper.

**No objections** were received arising from the public consultation process.

### **CRITERIA IN MAKING LICENSING DECISIONS**

The Minister, in considering an application for a Foreshore Licence, may, if satisfied that it is in the public interest to do so, grant such a licence. Section 82 of the Fisheries (Amendment) Act, 1997 stipulates that the Minister, in considering an application for a licence under the Foreshore Acts, which is sought in connection with the carrying on of aquaculture pursuant to an Aquaculture Licence, shall have regard to any decision of the licensing authority in relation to the Aquaculture Licence.

#### **RECOMMENDATION**

It is recommended that the Minister, taking account of the decision on the related Aquaculture Licence application:

**refuses to grant** the Foreshore Licence sought. The reason for the recommendation to refuse the granting of the application is as follows:

At current stocking levels in Killary Harbour there is significant competition for food resources which has resulted in a poor production yield of mussels, a lower product quality and longer growing time for some producers. The Licensing of additional production sites would compound this issue further.

Submitted for approval, please.

Deirdre O'Flynn

Aquaculture and Foreshore Management Division



**Marine Engineering Division**  
**Report on Aquaculture Licence Application**

**Application Reference No:** T09/511

**Report Prepared By:** Edwina Forde

**Date:** 19/02/19

**Applicant** Kevin & Michael Lydon, Cluggam, Maam, Co. Galway

**Location** Inner Killary Harbour

**Applicant Type** Aquaculture/Foreshore Licence Application

**Sites**

T09/511
---------

**Site Area (Ha)**

1.0
-----

**Species** Blue Mussels (*Mytilus Edulis*)

**Cultivation Method** Extensive- longlines

**Intertidal/Non-Intertidal** Sub-tidal

**Source of seed** Seed collection site

**Annual Production Estimates** 15 tonne (Year 5)

**Shellfish Waters Designation** Yes  No   
Reference: SI 268 of 2006

**Environmental Designation** Yes  No   
Reference: Adjacent to The Twelve Bens/Garraun complex  
SAC(0020131) and Mweelrea/Sheeffry/Eriff complex  
SAC ( 001932)

**Development Plans** Yes  No   
Reference: Galway County Development Plan 2015-2021  
Objective AFF8 - Aquaculture

**Pre-Consultation Meeting** Yes  No   
Date:

## Drawing Validation Sheet

**OSI Maps**

Yes  No

Comment:

6" scale maps prepared by GIS Mapping Section.

**BA Chart**

Yes  No

Comment:

BA Charts prepared by GIS Mapping Section.

**Farm Layout Drawing**

Yes  No

Directional Arrow Yes  No

Scale Yes  No

Title Block Yes  No

Date Yes  No

Comment:

Drawings submitted are suitable.

**Drawings of structures**

Yes  No

Comment:

Drawings submitted are suitable

**Details of Proposed**

**Navigation Marking**

Yes  No

Comment:

Drawings submitted are suitable

**Site Access Indicated**

Yes  No

Comment:

Site access map submitted is suitable

**Site Co-Ordinates**

**Indicated**

Yes  No

Comment:

Site co-ordinates indicated in application.

**Site Overlap**

Yes  No

Comment:

**Oyster Fishery Order**

**Overlap**

Yes  No

Comment:

**The application is submitted with each of the requirements listed and is therefore deemed to be a valid application.**

**AFMD should be aware that insufficient details have been submitted as per above.**



# Site Suitability Assessment

## Site Location

The site is located on the south shore of Inner Killary Harbour, Co. Galway. The 1.0 Ha site is a new application for previously licensed site T09/318B. Killary Harbour is a fjord-like inlet situated between the county boundaries of Mayo to the north and Galway to the south. It is approximately 15km long and 0.75km wide with an average depth of 15m. As high mountainous ground surrounds the water body, freshwater runoff is a significant factor in its hydrography. Killary Harbour is largely sheltered from wind and wave action making it an ideal area for aquaculture. Access to this site is by boat only. This aquaculture has been in existence for 20 years, which indicates that the hydrodynamic regime is suitable for this type of aquaculture. At present there are major problems in Killary Harbour's existing sites due to overstocking, lack of growth and seed availability. This site is situated adjacent to the south shore and adjoining existing sites, 2 of which are already licensed to this applicant. This is an opportunity to leave this area fallow and encourage greater flow of water through the system and improve settlement. The Wild Atlantic Way runs along the R335 on the north shore to Ashleigh and joins the N59 along the south shore to Letterfrack; this site can be viewed directly from the route. Appropriate Site Location maps have been submitted with this application.

## Site Management

This application is for aquaculture activity in Killary Harbour, Co. Galway. Access is by boat from Bundorragha Pier on the north shore of Killary. This site was previously licensed for mussel seed collection. The applicant proposes to place 3No longlines on this 1.0ha site. 3No longlines exceeds the usual 2No longlines per Ha throughout Killary Harbour. Mussels will be harvested on board a mussel boat, where they are graded and sorted into 1tonne bags or 20kg bags for sale to fresh market or processing.

## Proposed Site Layout and Structures

The aquaculture sites in Killary Harbour have been configured to facilitate navigation, farming operations, and visual impact within the overall aquaculture area. This applicant proposes to cultivate mussels using a maximum of 3No double headed longlines laid out almost parallel to the shore on a site 1.0 Ha in size. The farm site layout and detail of structures to be licensed for this application have been prepared and are suitable for advertising and attachment to any licence issued for the site. All structures including anchors are to be kept within the site boundary.

## Land Based Facilities / Site Access

The operator proposes to access the site using a boat from Bundorragha Pier located on the north shore of inner Killary Harbour. Details of the access route were included with the application.

## Navigation

The proposed navigational marking scheme should be approved by CIL. Applicant is to maintain all navigation markers as specified by the license. A SUMS is in operation in Killary Harbour.

## Visual Impact

The Galway County Development Plan 2015-2021 indicates there are scenic routes surrounding Killary Harbour. The aquaculture in Killary Harbour has been in place for the last 30 years and has become embedded in the landscape. The types of structures adhere to the best practices outlined in the Guidelines for Landscape and Visual Impact Assessment of Marine Aquaculture, 2001. The licence conditions will specify the orientation and colour of the structures on the sites to minimise the visual impact. All structures that are not in use will be removed from the foreshore.

**Impact / Cumulative Impact**

There has been licensed aquaculture activity in Killary Harbour for the last 30 years. There is tourism, fishing and marine leisure in the area. Aquaculture operations should not interfere with these amenities. At present there are major problems in Killary Harbour's existing sites due to overstocking, lack of growth and seed availability, leaving this area fallow will improve seed settlement in the surrounding sites as per the UISCE report recommendations. As the mussel production sites in Killary Harbour are not located within a Natura 2000 sites there will be no direct impacts from the operations. The Twelve Bens/Garraun complex SAC (0020131) to the south and the Mweelrea/Sheeffry/Eriff complex SAC (001932) to the north should be consulted for details of the aquaculture activity that may pose a potential significant negative impact on the SACs.

**Marine Engineering Division does not recommend the licencing of this site for the reasons outlined above.**

**Hall, Mary**

---

**From:** Hurley, Marita  
**Sent:** 26 January 2016 09:20  
**To:** Hall, Mary  
**Subject:** Foreshore Application T9/511 Kevin and Michael Lydon  
**Attachments:** T9-511 Kevin and Michael Lydon.pdf

Good Morning Mary,

Observations from our Ros An Mhil office.

Regards,

Marita

---

**From:** Murray, Paul  
**Sent:** 25 January 2016 15:42  
**To:** Hurley, Marita  
**Cc:** Nalty, Christopher; Curran, Siubhan  
**Subject:** FW: Foreshore Application T9/511 Kevin and Michael Lydon

Hi Marita,

Re the attached application my understanding is that this is a new application for a lapsed licence (T09/318B ) formerly granted to a Mr John Duane but never operated by him.

SFPA have no difficulty with the application proceeding in Mr Kevin/Michael Lydon's names subject to Dept engineers etc being satisfied that all necessary remedial works are carried out as per their requirements,

Kind regards,

Paul .

---

**From:** Hurley, Marita  
**Sent:** 08 January 2016 10:41  
**To:** Murray, Paul  
**Subject:** Foreshore Application T9/511 Kevin and Michael Lydon

Good Moring Paul,

Please find attached foreshore application for Killary Bay, Co. Galway.

Regards,

Marita

Marita Hurley  
Fisheries Control Unit  
Tel: 023-8859327



Rinville,  
Oranmore,  
Co. Galway  
Tel: 091 387200  
Date: 10 April 2019

Deirdre O'Flynn  
Aquaculture and Foreshore Management Division  
Department of Agriculture, Food and the Marine  
Clogheen,  
Clonakilty  
Co. Cork.

**Advice on Aquaculture Licence Application**

<b>Applicant</b>	<b>Kevin and Michael Lydon</b>
<b>Application type</b>	<b>New</b>
<b>Site Reference No</b>	<b>T09/511A</b>
<b>Species</b>	<b>Mussels (<i>M. edulis</i>) – longlines</b>
<b>Site Status</b>	<b>Not located within a Natura 2000 Site Located within the Killary designated Shellfish Growing Waters Area.</b>

Dear Deirdre

This is an application for an aquaculture licence to cultivate mussels (*M. edulis*), using longlines, at Site T09/511A in Killary Harbour, Co. Galway. The area of foreshore at Site T09/511A is circa 1.0Ha.

No chemicals or hazardous substances will be used during the production process.

The cultivation of shellfish at this site will produce faeces and pseudofaeces. Any impact will be limited to the area of the site. The build-up of excess organic matter beyond the footprint of the sites is not considered likely.

Considering the location, nature and scale of the proposed aquaculture activity, and in deference to our remit under the Marine Institute Act, and the considerations implicit to Sections 61(e and f) of the Fisheries (Amendment) Act, 1997 the Marine Institute is of the view that there will be no significant impacts on the marine environment and that the quality status of the area will not be adversely impacted

Site T09/511A is located within the Killary designated Shellfish Growing Water Area.

Under Annex II of EU Regulation 854/2004 mussels in Killary Harbour have a “B” Classification

Site T09/511A is not located within a designated Natura 2000 site and, as set out in the AA Screening Report for Killary Harbour<sup>1</sup>, the Marine Institute is of the view that significant impacts on any adjacent Natura 2000 are not likely.

The Marine Institute is of the view that at current stocking levels in Killary Harbour there is significant competition for food within Killary which has resulted in a poor production yield of mussels, a lower product quality and a longer growing time for some producers (ALAB Technical Advisor's report<sup>2</sup>, Nunes et al 2011<sup>3</sup>). The licencing of additional

1

<https://www.agriculture.gov.ie/media/migration/seafood/aquacultureforeshoremanagement/aquaculturelicensing/appropriateassessments/galway/AAScreeningKillaryHarbour280219.pdf>

2

[http://www.alab.ie/media/alab/content/technicalreports/JN1204%20ALAB%20Final%20Draft%20Killary%20Report%20\(includes%20corrections%20in%20Appendix%20I\).pdf](http://www.alab.ie/media/alab/content/technicalreports/JN1204%20ALAB%20Final%20Draft%20Killary%20Report%20(includes%20corrections%20in%20Appendix%20I).pdf)

production sites would compound this issue further. On this basis, the Marine Institute recommends that an aquaculture licence for the production of mussels at this site should not be granted.

In the event that an Aquaculture Licence is granted, and in order to be able to assess and manage the potential risk of the introduction of invasive non-native species, the MI recommends that the initial source of seed and other sources which may be used at any point in the future should be approved by the Minister. This approval should be a specific condition of any licence that may issue. It should be noted that the control of alien species is a separate issue to the control of diseases in the context of the current Fish Health legislation.

Notwithstanding the recommendation outlined above, and in the event that an Aquaculture Licence is granted, the movement of stock in and out of the site should follow best practice guidelines as they relate to the risk of introduction of invasive non-native species (e.g. [Invasive Species Ireland](#)). In this regard it is recommended that, prior to the commencement of operations at the site, the applicant be required to draw up a contingency plan, for the approval of DAFM, which shall identify, *inter alia*, methods for the removal from the environment of any invasive non-native species introduced as a result of operations at this site. If such an event occurs, the contingency plan shall be implemented immediately.

In the event that invasive non-native species are introduced into a site as a result of aquaculture activity the impacts may be bay-wide and thus affect other aquaculture operators in the bay. In this regard, therefore, the Marine Institute considers that the CLAMS process may be a useful and appropriate vehicle for the development and implementation of alien species management and control plans.

It is statutory requirement that a Fish Health Authorisation as required under Council Directive 2006/88/EC be in place prior to the commencement of the aquaculture activities proposed.

Kind regards,

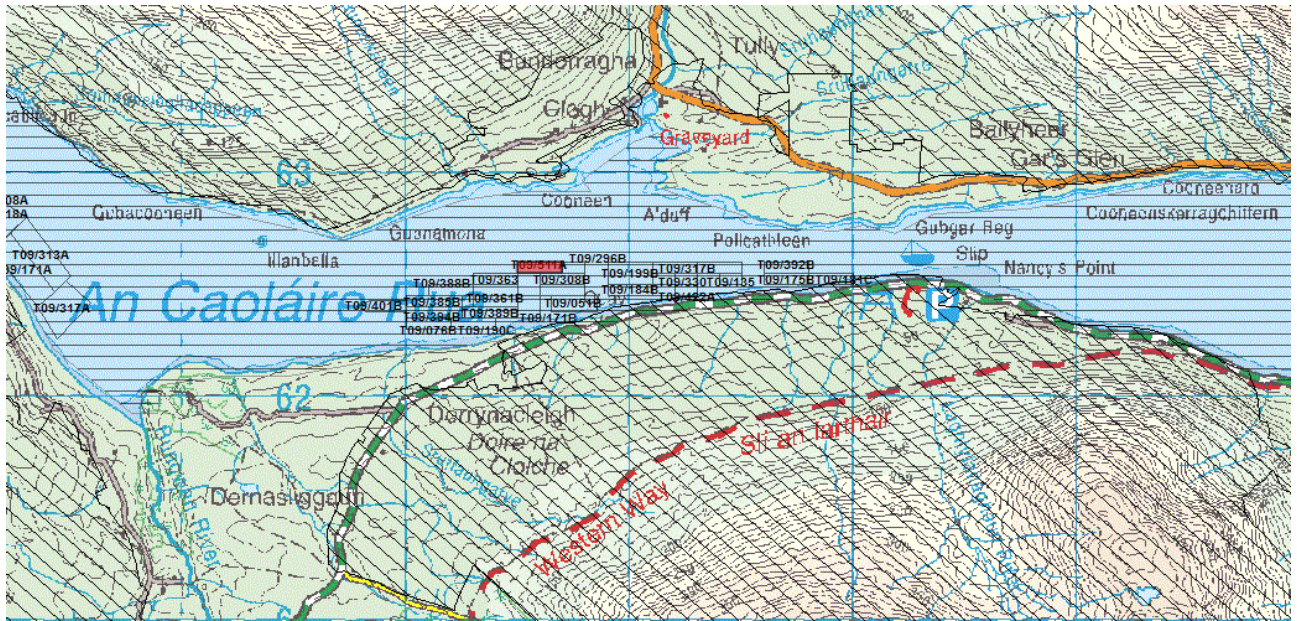



---


Dr. Terry McMahon  
Section Manager, Marine Environment and Food Safety Services,  
The Marine Institute.


---


<sup>3</sup> Nunes J.P. et al. 2011. Towards an ecosystem approach to aquaculture: Assessment of sustainable shellfish cultivation at different scales of space, time and complexity. *Aquaculture* 315 (2011) 369–383



Shellfish Waters Directive Area  


Aquaculture Site  


Special Area of Conservation  


Special Protection Areas  




## Applications for new Aquaculture Licence Sites, in Killary Harbour, Co Galway;

**T09-511**

Inland Fisheries Ireland previously expressed serious concern about the excessive number of licences issued in Killary Harbour for the cultivation of mussels and the concern of Inland Fisheries Ireland (previously the Western Regional Fisheries Board) has been reflected in the decreased growth rates achieved in the bay since the substantial increase in the number of licences in the bay.

Consideration must be given to the production capacity of the bay which by virtue of the fact that these farms rely on natural production for growth is very limited. Mussels are filter feeders and fed exclusively on the planktonic foodstuffs in the bay. This is dictated by the natural production capacity of the bay. Regardless of the number of mussels alive in the bay only a specific biomass can be grown annually.

Inland Fisheries Ireland is calling on the Department to commission a new study on the bay to ascertain the correct carrying capacity of the bay in terms of annual production that the bay can create and to licence the correct number of operators and tonnage accordingly.

It is noted that one of the new applicants previously appealed a decision to the Aquaculture Licence Appeals Board (ALAB) to renew a shellfish licence application in 2013 unless a number of conditions were implemented on the granting of said licence. As per the Aquafact Report which accompanied the appeal, the appellant maintained that over-licensing in Killary Harbour has resulted in a culture of over-stocking resulting in diminished phytoplankton food supply for some producers, stating that with the proliferation of licences, some farms have been surrounded by others and as such, a fair and equitable access to food supply is precluded.

Nunes *et al.*, (2011) research paper estimated that the maximum mussel production of the Killary Harbour system is 4,200 tonnes per year, but achieving this level would lead to lower harvest weights and longer growth cycles.

However, Killary Bay has been shown scientifically to be unable to support this level of production (Rodhouse & Roden 1987). The limit proposed prior to the farming having a significant deleterious effect on the bay is just 3,000 tonnes per annum. On the basis of the existing scientific data the issuing of any further long line shellfish licences in Killary Harbour would be both scientifically unsound and economically unwise. The nett result would be that more shellfish farmers would be attempting to exploit a finite resource with a limited production capacity. This could lead to all the Mussel businesses in the bay, both existing and proposed, being made unviable.

In view of the scientific evidence and all the other reasons proposed as well as the current licensed production the issuing of any new licences would be improper.

Furthermore Killary Harbour has suffered from algal blooms annually that render the shellfish in the bay toxic if consumed by humans. This is a further reason for the limiting of the producers and the capping of production of Mussels in the bay.



## **References:**

- (Aquafact, AP2/2013, Killary Mussel Licence Renewal Appeal, Site T9/317, Technical Advisors Report, Produced by AQUAFAC International Services Ltd On behalf of Aquaculture Licences Appeals Board).
- Nunes, J. P., J. G. Ferreira, S. B. Bricker, B. O'Loan, T. Dabrowski, B. Dallaghan, A. J. S. Hawkins, B. O'Connor, and T. O'Carroll. Towards an ecosystem approach to aquaculture: Assessment of sustainable shellfish cultivation at different scales of space, time and complexity. *Aquaculture* **315**, no. 3 (2011): 369-383.
- Rodhouse, P.G. & Roden, C.M. 1987. Carbon budget for a coastal inlet in relation to intensive cultivation of suspension-feeding molluscs. *Marine Ecology Progress Series*. **36**, 225–236.



Ms. Deirdre O' Flynn  
Aquaculture and Foreshore Management Division  
Dept. of Agriculture Food & the Marine  
National Seafood Centre  
Clonakilty  
Co. Cork

*Your Reference:* T09/511

*Our Reference:* LA:0435.2735

*Date:* 28/03/2019

**LL: LA 0435.2735**

**Applicant:** Kevin & Michael Lydon

**Site:** Killary Harbour, Co. Galway

Dear Ms. O' Flynn,

Thank you for your letter advising us of this application.

Based on the information supplied, there appears to be no objection to the development. It is important to ensure that no navigable inter-tidal channels are impeded by the site.

If a licence is granted, all structures must be clearly marked as required by Regulations and Licensing Permit conditions and to the approval of the Nautical Surveyor with the Marine Survey Office.

We would request that you include the following terms in the licence—

- That the applicant secures Statutory Sanction from the Commissioners of Irish Lights for the aids to navigation that may be required by the Marine Survey Office. These aids should be in place before development on the site commences. Statutory sanction forms are available at <http://www.irishlights.ie/safety-navigation/statutory-sanction.aspx>
- The size and specification of aids to navigation should be of the design and specification approved by the Marine Survey Office and must be agreed in advance with the Commissioners of Irish Lights.

It is recommended that local fishing and leisure interests be consulted prior to a decision being made.

Furthermore, if a licence is granted, the UK Hydrographic Office at Taunton: [sdr@ukho.gov.uk](mailto:sdr@ukho.gov.uk) must be informed of the development's geographical position in order to update nautical charts and other nautical publications.

Yours sincerely,

**Neil Askew**  
**for Director of Operations and Navigation**

cc Capt. T. O'Callaghan, Dept. of Transport Tourism & Sport, Marine Survey Office

**OFlynn, Deirdre**

---

**From:** Murphy, Mike [murphym@bim.ie]  
**Sent:** 08 May 2019 11:07  
**To:** OFlynn, Deirdre  
**Subject:** RE: Aquaculture Licence applications in Killary Harbour, Co Galway

**CAUTION:** This email originated from outside of the organisation. Do not click links or open attachments unless you recognise the sender and know the content is safe.

Dear Deirdre,

Re: Licence Applications/Renewal in Killary Harbour, in Co. Galway, [REDACTED]; T09/511, to grow mussels on longlines.

Following internal consultation within the Seafood Technical Services Business Unit, BIM, which includes aquaculture and inshore fisheries, BIM are satisfied that the proposed operations do not conflict with any other aquaculture or inshore fisheries interests in the area.

We have no objection to the renewal/applications.

Regards

Mike Murphy

**Michael Murphy**

Resource Development Manager North,  
Seafood Technical Services Business Unit,  
**BIM**

T +353 7479732601

M +353 87 2476448

E [mike.murphy@bim.ie](mailto:mike.murphy@bim.ie)

[REDACTED]

[REDACTED]

The information contained in this email and in any attachments is confidential and is designated solely for the attention and use of the intended recipient(s). This information may be subject to legal and professional privilege. If you are not an intended recipient of this email, you must not use, disclose, copy, distribute or retain this message or

any part of it. If you have received this email in error, please notify the sender immediately and delete all copies of this email from your computer system(s).

An Roinn Talmhaíochta, Bia agus Mara

Tá an t-eolais san ríomhphost seo, agus in aon ceanglín leis, faoi phribhléid agus faoi rún agus le h-agmaigh an seolaí amháin. D'fhéadfadh ábhar an seoladh seo bheith faoi phribhléid profisiúnta nó dlíthiúil. Mura tusa an seolaí a bhí beartaithe leis an ríomhphost seo a fháil, tá cosc air, nó aon chuid de, a úsáid, a chóipeál, nó a scaoileadh. Má tháinig sé chugat de bharr dearmad, téigh i dteagmháil leis an seoltóir agus scríos an t-ábhar ó do ríomhaire le do thoil.

Kevin and Michael Lydon,  
Cluggam,  
Maam,  
Co. Galway.  
H91 EHK8

Ms Deirdre O'Flynn.  
Aquaculture and Foreshore Management Division,  
Department of Agriculture, Food and the Marine,  
National Seafood Centre,  
Clogheen,  
Clonakilty,  
Co. Cork.  
P85 TX47



30th May 2019

**Re: Applications for Aquaculture Licence Sites in Killary Harbour, Co. Galway;  
T09/509, T09/510 and T09/511.**

Dear Ms O'Flynn.

As requested, here is our response to the comments and observations received as a result of the statutory consultation stage of the application process for Licences No. T09/509, T09/510 and T09/511.

IFI have objected to the granting of all three licences and the Marine Institute to T09/510 and T09/511 on the grounds of over-stocking in Killary Harbour. All of these sites are in the inner bay where there are no growth problems. Whilst they are new licences, these sites were previously licenced along with all current licences, but still there was no major growth issues in the inner bay as can be confirmed by the Carrying Capacity Report 2010.

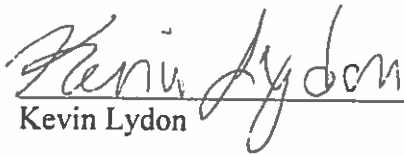
With regards to the Marine Institute concerns over the introduction of invasive non-native species, in our thirty-five years of mussel farming in Killary Harbour there has always been sufficient spat collection naturally in the bay for production purposes. Spat quantities do fluctuate from season to season and in the most unlikely event of a total collapse we would not like to see any seed be introduced to Killary Harbour due to the possible detrimental damage it could cause.

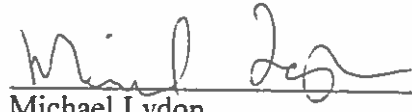
With regards to IFI concerns over algal blooms, Killary Harbour usually has very low levels of blooms and in some years, none at all. There is a very robust monitoring programme in place conducted by the Marine Institute to alert producers if toxic blooms are imminent. This allows the producers to take appropriate action to safeguard human health.

With regards to the Commissioners of Irish Lights, we are happy to comply with their recommendations.

Finally, we are glad to note that BIM, technical advisors to DAFM, have no objections to the granting of the licences.

Yours sincerely,

  
Kevin Lydon

  
Michael Lydon

**Appropriate Assessment Screening for Aquaculture activities in Killary Harbour, Co. Galway**

Brief description of the project or plan	<p>Currently mussels (<i>Mytilus edulis</i>) are cultured at 52 licenced sites and salmon (<i>Salmo salar</i>) are cultured at 2 licenced sites in the Killary Harbour area. The culture of salmon takes place at the 2 most western sites while the culture of mussels takes place within the harbour area.</p> <p>Applications have been submitted for aquaculture licences for the production of mussels at 9 additional sites and for the production of oysters at 1 additional site (in Little Killary).</p> <p>The location of all sites, both licenced and applications, are shown in Figure 1</p>
--	---

Brief description of the Natura 2000 sites	<p>Killary Harbour is not a Natura 2000 site but is bordered by 4 SACs - The Twelve Bens/Garraun Complex SAC (Site Code: 002031), the Mweelrea/Sheeffry/Erriff Complex SAC (Site Code: 001932) the Maumturk Mountains SAC (Site Code: 002008) and the West Connacht Coast SAC (Site Code 002998). The locations of these sites are also shown in Figures 1, 2 &amp; 3.</p> <p><b>Twelve Bens/Garraun Complex SAC (Site Code: 002031)</b>          This is an extensive site situated in the north-west of Connemara in Co. Galway and dominated by mountainous terrain. The site is bounded to the south by the Connemara Bog Complex, to the east by the Maumturk Mountains and to the north by Killary Harbour. Included within the site are the Twelve Bens mountain range, the mountains to the north of Kylemore (Doughruagh, Garraun and Benchoona), rivers including the Ballynahinch and Owenglin systems and an area of coastal heath and machair near Glassilaun. The site also includes some extensive tracts of lowland blanket bog which are continuous with the mountains</p> <p>The Conservation Objectives of this site are<sup>1</sup>:</p> <ul style="list-style-type: none"> <li>• To maintain the favourable conservation condition of Oligotrophic waters containing very few minerals of sandy plains (<i>Littorelletalia uniflorae</i>) in The Twelve Bens/Garraun Complex SAC,</li> <li>• To maintain the favourable conservation condition of Oligotrophic to mesotrophic standing waters with vegetation of the <i>Littorelletea uniflorae</i> and/or of the <i>Isoëto-Nanojuncetea</i> in The Twelve Bens/Garraun Complex SAC,</li> <li>• To restore the favourable conservation condition of Alpine and Boreal heaths in The Twelve</li> </ul>
--	--

<sup>1</sup> NPWS (2017) Conservation Objectives: The Twelve Bens/Garraun Complex SAC 002031. Version 1. National Parks and Wildlife Service, Department of Arts, Heritage, Regional, Rural and Gaeltacht Affairs.

	<p>Bens/Garraun Complex SAC,</p> <ul style="list-style-type: none"> <li>• To restore the favourable conservation condition of Blanket bogs (* if active bog) in The Twelve Bens/Garraun Complex SAC,</li> <li>• To restore the favourable conservation condition of Depressions on peat substrates of the Rhynchosporion in The Twelve Bens/Garraun Complex SAC,</li> <li>• To restore the favourable conservation condition of Siliceous scree of the montane to snow levels (Androsacetalia alpinae and Galeopsietalia adani) in The Twelve Bens/Garraun Complex SAC</li> <li>• To restore the favourable conservation condition of Calcareous rocky slopes with chasmophytic vegetation in The Twelve Bens/Garraun Complex SAC,</li> <li>• To restore the favourable conservation condition of Siliceous rocky slopes with chasmophytic vegetation in The Twelve Bens/Garraun Complex SAC,</li> <li>• To maintain the favourable conservation condition of Old sessile oak woods with Ilex and Blechnum in the British Isles in The Twelve Bens/Garraun Complex SAC,</li> <li>• To restore the favourable conservation condition of Freshwater Pearl Mussel in The Twelve Bens/Garraun Complex SAC,</li> <li>• To maintain the favourable conservation condition of Atlantic Salmon in The Twelve Bens/Garraun Complex SAC,</li> <li>• To maintain the favourable conservation condition of Otter in The Twelve Bens/Garraun Complex SAC,</li> <li>• To maintain the favourable conservation condition of Slender Naiad in The Twelve Bens/Garraun Complex SAC,</li> </ul> <p><b>Mweelrea/Sheeffry/Erriff Complex SAC (Site Code: 001932)</b></p> <p>The Mweelrea/Sheeffry/Erriff Complex SAC covers a large area of the scenic hills of south Co. Mayo. The western limit of the site is at Dooaghtry, south of Kinnadoohy. The southern margin is bounded by Killary Harbour and the Erriff River, including the corrie of Lough Glenawough. The Aille River forms the eastern limit, and to the north the boundary includes the main massifs of the Sheeffry Hills and the Mweelrea Mountains. Several river catchments are encompassed within the site, including the Bundorragha and Glenummera Rivers, as well as Fin Lough, Doo Lough and Glencullin Lough, the upper catchment of the Bunowen River and parts of the Derrycraft and Owenmore Rivers.</p>
--	---



	<p>The Conservation Objectives of this site are:<sup>2</sup></p> <ul style="list-style-type: none"> <li>• To restore the favourable conservation condition of Coastal lagoons* in Mweelrea/Sheeffry/Erriff Complex SAC</li> <li>• To maintain the favourable conservation condition of Annual vegetation of drift lines in Mweelrea/Sheeffry/Erriff Complex SAC,</li> <li>• To restore the favourable conservation condition of Atlantic salt meadows (<i>Glauco-Puccinellietalia maritima</i>) in Mweelrea/Sheeffry/Erriff Complex SAC,</li> <li>• To restore the favourable conservation condition of Mediterranean salt meadows (<i>Juncetalia maritimi</i>) in Mweelrea/Sheeffry/Erriff Complex SAC,</li> <li>• To maintain the favourable conservation condition of Embryonic shifting dunes in Mweelrea/Sheeffry/Erriff Complex SAC,</li> <li>• To maintain the favourable conservation condition of Oligotrophic waters containing very few minerals of sandy plains (<i>Littorelletalia niflorae</i>) in Mweelrea/Sheeffry/Erriff Complex SAC,</li> <li>• To maintain the favourable conservation condition of Oligotrophic to mesotrophic standing waters with vegetation of the <i>Littorelletea uniflorae</i> and/or of the <i>Isoëto-Nanojuncetea</i> in Mweelrea/Sheeffry/Erriff Complex SAC,</li> <li>• To maintain the favourable conservation condition of Natural dystrophic lakes and ponds in Mweelrea/Sheeffry/Erriff Complex SAC,</li> <li>• To maintain the favourable conservation condition of Water courses of plain to montane levels with the <i>Ranunculion fluitantis</i> and <i>Callitricho-Batrachion</i> vegetation in Mweelrea/Sheeffry/Erriff Complex SAC,</li> <li>• To restore the favourable conservation condition of Northern Atlantic wet heaths with <i>Erica tetralix</i> in Mweelrea/Sheeffry/Erriff Complex SAC,</li> <li>• To restore the favourable conservation condition of European dry heaths in weelrea/Sheeffry/Erriff Complex SAC,</li> <li>• To restore the favourable conservation condition of Alpine and Boreal heaths in Mweelrea/Sheeffry/Erriff Complex SAC,</li> <li>• To maintain the favourable conservation condition of <i>Juniperus communis</i> formations on heaths or calcareous grasslands in Mweelrea/Sheeffry/Erriff</li> </ul>
--	---

---

<sup>2</sup> NPWS (2017) Conservation Objectives: Mweelrea/Sheeffry/Erriff Complex SAC 001932. Version 1. National Parks and Wildlife Service, Department of Culture, Heritage and the Gaeltacht

	<p>Complex SAC,</p> <ul style="list-style-type: none"> <li>• To maintain the favourable conservation condition of Hydrophilous tall herb fringe communities of plains and of the montane to alpine levels in Mweelrea/Sheeffry/Erriff Complex SAC,</li> <li>• To restore the favourable conservation condition of Blanket bogs (* if active bog) in Mweelrea/Sheeffry/Erriff Complex SAC,</li> <li>• To restore the favourable conservation condition of Transition mires and quaking bogs in Mweelrea/Sheeffry/Erriff Complex SAC,</li> <li>• To restore the favourable conservation condition of Depressions on peat substrates of the Rhynchosporion in Mweelrea/Sheeffry/Erriff Complex SAC,</li> <li>• To maintain the favourable conservation condition of Petrifying springs with tufa formation (Cratoneurion)* in Mweelrea/Sheeffry/Erriff Complex SAC,</li> <li>• To restore the favourable conservation condition of Alkaline fens in Mweelrea/Sheeffry/Erriff Complex SAC,</li> <li>• To restore the favourable conservation condition of Siliceous scree of the montane to snow levels (Androsacetalia alpinae and Galeopsietalia ladani) in Mweelrea/Sheeffry/Erriff Complex SAC,</li> <li>• To maintain the favourable conservation condition of Calcareous rocky slopes with chasmophytic vegetation in Mweelrea/Sheeffry/Erriff Complex SAC,</li> <li>• To restore the favourable conservation condition of Siliceous rocky slopes with chasmophytic vegetation in Mweelrea/Sheeffry/Erriff Complex SAC,</li> <li>• To maintain the favourable conservation condition of Geyer's Whorl Snail in Mweelrea/Sheeffry/Erriff Complex SAC,</li> <li>• To maintain the favourable conservation condition of Narrow-mouthed Whorl Snail in Mweelrea/Sheeffry/Erriff Complex SAC,</li> <li>• To restore the favourable conservation condition of Freshwater Pearl Mussel in Mweelrea/Sheeffry/Erriff Complex SAC,</li> <li>• To restore the favourable conservation condition of Atlantic Salmon in Mweelrea/Sheeffry/Erriff Complex SAC,</li> <li>• To maintain the favourable conservation condition of Otter in Mweelrea/Sheeffry/Erriff Complex SAC,</li> <li>• To maintain the favourable conservation condition of Petalwort in Mweelrea/Sheeffry/Erriff Complex SAC,</li> <li>• To maintain the favourable conservation condition of Slender Naiad in Mweelrea/Sheeffry/Erriff Complex SAC,</li> </ul>
--	--

#### **Maumturk Mountains SAC (Site Code: 002008)**

The Maumturk Mountains are situated east of the Twelve Bens and west of the Maumtrasnas, between the Inagh Valley and the Leenaun/Maam road in Co. Galway. The site is bounded to the north by Killary Harbour and to the south by the Galway/ Clifden road. Most of the mountains exceed 600 m in height and about half of the land within the site lies above an altitude of 250 m. In addition many rivers criss-cross the site.

The Conservation Objectives of this site are<sup>3</sup>

- To maintain the favourable conservation condition of Oligotrophic waters containing very few minerals of sandy plains (*Littorelletalia uniflorae*) in Maumturk Mountains SAC,
- To restore the favourable conservation condition of Northern Atlantic wet heaths with *Erica tetralix* in Maumturk Mountains SAC,
- To restore the favourable conservation condition of Alpine and Boreal heaths in Maumturk Mountains SAC,
- To restore the favourable conservation condition of Blanket bogs (\* if active bog) in Maumturk Mountains SAC,
- To restore the favourable conservation condition of Depressions on peat substrates of the *Rhynchosporion* in Maumturk Mountains SAC,
- To restore the favourable conservation condition of Siliceous rocky slopes with chasmophytic vegetation in Maumturk Mountains SAC,
- To maintain the favourable conservation condition of Atlantic Salmon in Maumturk Mountains SAC,
- To maintain the favourable conservation condition of Slender Naiad in Maumturk Mountains SAC,

#### **West Connacht Coast SAC (Site Code 002998)**

This site consists of a substantial area of marine waters lying off the coasts of Counties Mayo and Galway. Comprising two parts, in its northern component the site extends from the coastal waters off Erris Head westwards beyond Eagle Island and the Mullet Peninsula in Co. Mayo. From there it extends southwards immediately off the coast as far as the entrance to Blacksod Bay. In its southern component, the site stretches from Clare Island and the outer reaches of Clew Bay at Old Head and continues southwards off the Mayo coast to the Connemara coast near Clifden and Ballyconneely, Co Galway. Predominantly coastal in nature,

<sup>3</sup> NPWS (2017) Conservation Objectives: Maumturk Mountains SAC 002008. Version 1. National Parks and Wildlife Service, Department of Arts, Heritage, Regional, Rural and Gaeltacht Affairs.

	<p>the site extends westwards into Atlantic continental shelf waters up to approximately 7-11 km from the mainland, although in its southern component it remains mostly inshore of the main islands: Clare Island, Inishturk, Inishbofin and Inishshark. Its area contains subtidal waters fringing these and other islands, as well as islets and rocky skerries off the Co. Mayo and Co. Galway coasts.</p> <p>The Conservation Objectives of this site are<sup>4</sup></p> <ul style="list-style-type: none"><li>• To maintain the favourable conservation condition of Common Bottlenose Dolphin in West Connacht Coast SAC,</li></ul>
--	---

---

<sup>4</sup> NPWS (2015) Conservation Objectives: West Connacht Coast SAC 002998. Version 1. National Parks and Wildlife Service, Department of Arts, Heritage and the Gaeltacht.

<b>Assessment criteria</b>	
<p>Describe the individual elements of the project (either alone or in combination with other plans or projects) likely to give rise to impacts on the Natura 2000 site.</p>	<p>Mussels are cultured using longlines. A long-line supported by a series of small floats joined by a cable or chain and anchored at the bottom on both ends is employed. Mussel spat (seed) is collected on ropes or strings (droppers) suspended on the line. From each of the longlines there are a number of dropper lines (up to 5m in length). The depth of the droppers is dependent upon a number of factors including water depth, the floatation provided and the carrying capacity of the system.</p> <p>Intertidal culture of oysters is carried out in bags on trestles in the intertidal zone. Depending on the size of the stock the numbers of oysters in each bag will vary with lower number in bags with larger oysters. Typically seed is sourced from hatcheries in the UK or France but when available may also be sourced from within Ireland.</p> <p>Finfish are contained in floating cages structures arranged in a grid system which are secured to the seabed via ropes attached to anchors. The fish are inputted to the cages as smolts, where they are fed, and following a period of 18- 24 months are harvested.</p> <p>Atlantic salmon (<i>Salmo salar</i>) is listed as a “Feature of Interest” in the Mweelrea/Sheeffry/Erriff Complex SAC, the Twelve Bens/Garraun Complex SAC and the Maumturk Mountains SAC. While all 3 designated sites support important populations and high quality spawning and nursery grounds for Atlantic salmon (<i>Salmo salar</i>) only salmon from Mweelrea/Sheeffry/Erriff Complex SAC use Killary harbour as a migratory route. The presence of aquaculture structures could potentially form a physical barrier to migration.</p> <p>Out migrating smolt abundance could potentially be impacted by sealice from the salmon cages at licenced Sites T09/143 and T09/143A in the area.</p> <p>Common Bottlenose Dolphin could be potentially be impacted by the proposed aquaculture activity at Site T09/478A (mussel application site), and Site T09/143A (licenced salmon farm site) which are both located within the West Connacht Coast SAC</p>

<p>Describe any likely direct, indirect or secondary impacts of the project (either alone or in combination with other plans or projects) on the Natura 2000 site by virtue of:</p>	
<p>size and scale;</p>	<p>With the exception of site T09/478A and T09/143A, both of which are located within the West Connacht Coast SAC, as well as Site T09/143, there are no direct or indirect impacts from the culture operations on the adjacent SACs.</p>

	<p>The aquaculture activity occurs principally on the south shore of the harbour and, considering the nature and scale of the aquaculture structures used in the area, is not considered to present a significant barrier to migration of salmon in the area. The aquaculture structures will not result in an artificial barrier to salmon migration within the river channels.</p> <p>Out migrating smolt abundance could potentially be impacted by sealice from the salmon cages in the area. (Sites T09/143 and T09/143) A further assessment of this issue is needed and should be fully considered as part of the determination of any application for the renewal of these aquaculture licences.</p>
Distance from the Natura 2000 site or key features of the site:	With the exception of site T09/478A and T09/143A, both of which are located within the West Connacht Coast SAC (there is no spatial overlap between any of the aquaculture sites and the Natura 2000 sites.
Resource requirements (water abstraction etc.):	<p>Cultured bivalves (mussels and oysters) are filter feeders and they feed upon suspended particulate matter. They selectively ingest phytoplankton and other organic material (e.g. small zooplankton and bacteria) and dispose of inorganic and larger organic matter in pseudofeces, which is excreted into the water column. Typically the fecal and pseudofecal pellets will fall to the sea floor and may cause localised organic enrichment and/or sedimentation. The level of enrichment is a function of, <i>inter alia</i>, water depth current speed, density of culture, the quantity of suspended particulate matter in the water column, or a combination of these. The build-up of excess organic matter beyond the footprint of the sites is not considered likely. The bivalve shellfish production activities do not use any resources required by the qualifying features within the adjacent Natura 2000 sites.</p> <p>Similarly the culture of salmon, which involves the use of pre-prepared feed, does not use any resources required by the qualifying features within the adjacent Natura 2000 sites. As is the case with bivalves salmon will produce fecal pellets which will fall to the sea floor and may cause localised organic enrichment and/or sedimentation. The level of enrichment is a function of, <i>inter alia</i>, water depth current speed, density of culture, the quantity of suspended particulate matter in the water column, or a combination of these. The build-up of excess organic matter beyond the footprint of the sites is not considered likely.</p>
Emissions (disposal to land, water or air):	<p>No toxic or hazardous chemicals are used during the culture of shellfish. Water quality will not be impacted.</p> <p>The aquaculture sites in the Killary harbour area are accessed mainly by boats, with other vehicles used as required. As a consequence, noise and pollution e.g. as a result of a fuel spill may present a risk to features of adjoining Natura sites with a specific marine element. The</p>

	risks are, however, not considered significant at current levels of aquaculture activity. It is considered that impacts would be localised and minor.
Excavation requirements:	There are no excavation or similar activities associated with the aquaculture activity
Transportation requirements:	With the exception of site T09/478A and T09/143A, both of which are located within the West Connacht Coast SAC, access routes to the aquaculture sites do not spatially overlap with any of the adjacent Natura 2000 sites. The produced aquaculture products are transported offsite by lorry using the existing national road network with no impact on the adjoining Natura 2000 sites.
Duration of construction, operation, decommissioning:	None
Other:	.

Describe any likely changes to the site arising as a result of:	
Reduction of habitat area:	With the exception of site T09/478A and T09/143A, both of which are located within the West Connacht Coast SAC, there is no reduction in habitat area within any of the Natura 2000 sites considered. arising from the currently licenced or proposed aquaculture production activities
Disturbance to key species:	With the exception of site T09/478A and T09/143A, both of which are located within the West Connacht Coast SAC as well as Site T09/143, and given the separation distance of the aquaculture sites from the adjacent Natura 2000 sites and the absence of any clear “source –pathway – receptor” there will be no disturbance to key species within any Natura 2000 sites arising from the currently licenced or proposed shellfish aquaculture production activities
Habitat or species fragmentation:	With the exception of site T09/478A and T09/143A, both of which are located within the West Connacht Coast SAC there is no habitat or species fragmentation within the Natura 2000 sites arising from the currently licenced or proposed aquaculture production activities
Reduction in species density:	With the exception of site T09/478A and T09/143A, both of which are located within the West Connacht Coast SAC, there is no reduction in species density within the Natura 2000 sites arising from the currently licenced or proposed aquaculture production activities.
Changes in key indicators of conservation value (water quality):	With the exception of site T09/478A and T09/143A, both of which are located within the West Connacht Coast SAC, there are no changes in key indicators of conservation value within the Natura 2000 sites arising from the currently licenced or proposed aquaculture production activities.
Climate change:	Given the nature and scale of the aquaculture production activities the contribution to climate change is considered insignificant.

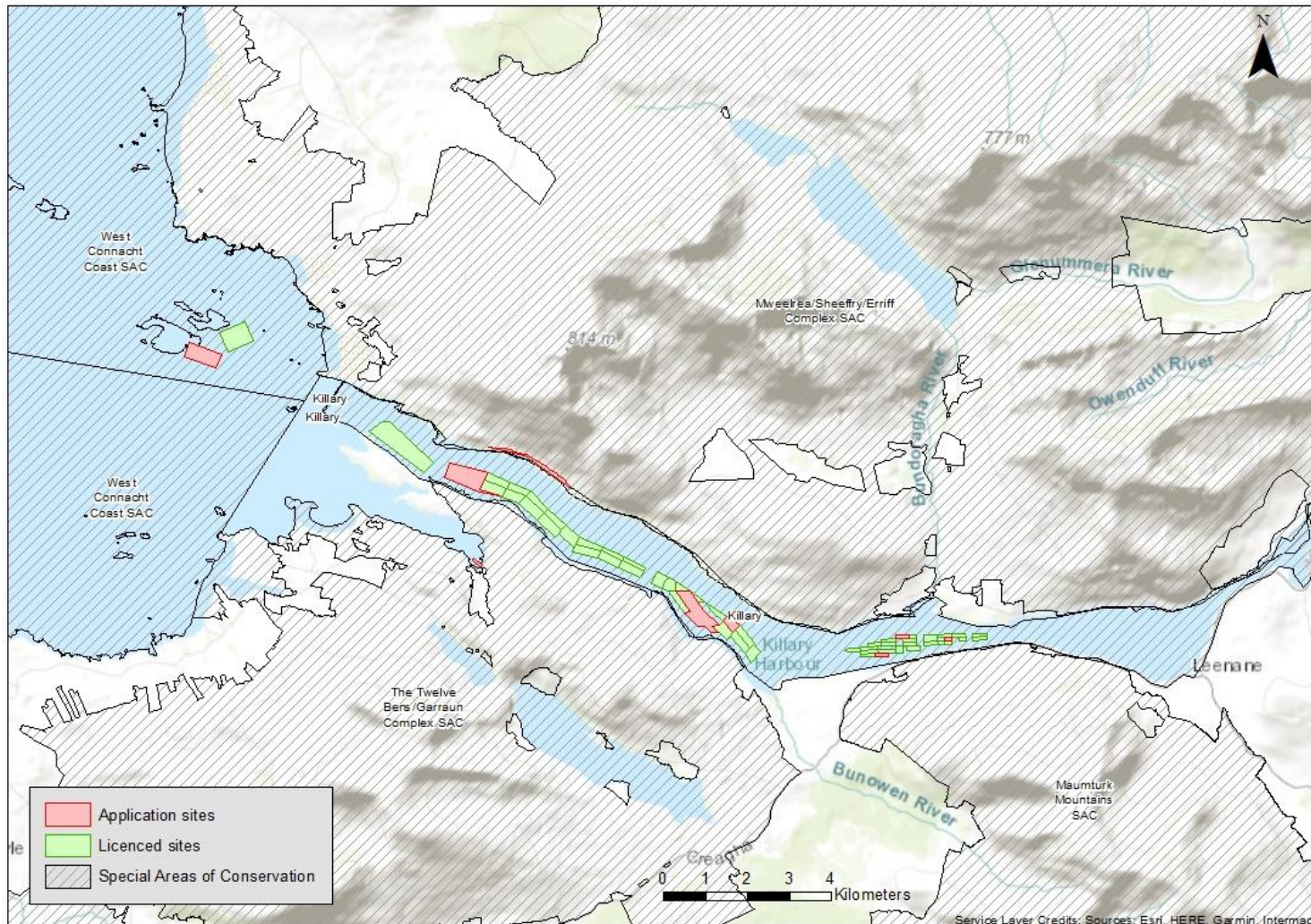
Describe any likely impacts on the Natura 2000 site as a whole in term of;	
Interference with the key relationships that define the structure of the site:	With the exception of site T09/478A and T09/143A, both of which are located within the West Connacht Coast SAC the currently licenced or proposed aquaculture production activities in Killary Harbour will not interfere with the key relationships that define the structure of the adjacent Natura 2000 sites.
Interference with the key relationships that define the function of the site	With the exception of site T09/478A and T09/143A, both of which are located within the West Connacht Coast SAC the currently licenced or proposed aquaculture production activities in Killary Harbour will not interfere with the key relationships that define the function of the adjacent Natura 2000 sites.
Provide indicators of significance as a result of the identification of effects set out above in terms of:	
Loss	With the exception of site T09/478A and T09/143A, both of which are located within the West Connacht Coast SAC, none identified
Fragmentation:	With the exception of site T09/478A and T09/143A, both of which are located within the West Connacht Coast SAC, none identified
Disruption:	With the exception of Site T09/143 and T09/143A, both of which are currently licenced for salmon culture and which could potentially impact on outgoing salmon smolt migration, none identified
Disturbance:	With the exception of site T09/478A and T09/143A, both of which are located within the West Connacht Coast SAC, none identified
Change to key elements of the site (e.g. water quality etc.):	With the exception of site T09/478A and T09/143A, both of which are located within the West Connacht Coast SAC, none identified
Describe from the above those elements of the project or plan, or combination of elements, where the above impacts are likely to be significant or where the scale or magnitude of impacts is not known.	With the exception of site T09/478A and T09/143A, both of which are located within the West Connacht Coast SAC as well as Site T09/143, none identified



<b>Finding of no significance effect report:</b>	
Name of project or plan:	Aquaculture activities in the Killary Harbour area.
Name and location of Natura 2000 site It would be helpful for a map or plan to be provided:	The Twelve Bens/Garraun Complex SAC (Site Code: 002031), the Mweelrea/Sheeffry/Erriff Complex SAC (Site Code: 001932) the Maumturk Mountains SAC (Site Code: 002008) and the West Connacht Coast SAC (Site Code 002998).
Description of the project or plan	Shellfish (mussels and oysters) and finfish (Atlantic salmon) culture activity in Killary Harbour.
Is the project or plan directly connected with or necessary to the management of the site (provide details)?	No.
Are there other projects or plans that together with the project or plan being assessed could affect the site (provide details)?	No.
Describe how the project or plan (alone or in combination) is likely to affect the Natura 2000 site.	With the exception of site T09/478A and T09/143A, both of which are located within the West Connacht Coast SAC as well as Site T09/143 cultivation of shellfish and finfish in Killary Harbour is not likely to affect the features of adjoining Natura 2000 sites.
Explain why these effects are not considered significant.	<p>With the exception of site T09/478A and T09/143A, both of which are located within the West Connacht Coast SAC there is no spatial overlap of the aquaculture activities with Natura sites. In addition, there would be no interference with key relationships that define the function of the sites. The shellfish culture activities will not result in habitat loss, there will not be significant disturbance to key species and there will be no habitat or species fragmentation. There will be no direct discharge of pollutants into the environment and water quality will not be affected. Consequently, it is concluded that the culture of shellfish, as it is currently constituted and proposed, in Killary Harbour does not pose significant risk to the conservation features of the adjacent Natura 2000 sites and as such does not require a full appropriate assessment.</p> <p>On the basis of the above it is considered that there will be no significant effects on the qualifying feature / interests' of the adjacent Natura 2000 sites.</p> <p>Given that the currently licenced aquaculture activity at Site T09/143A and the proposed licenced aquaculture activity at Site T09/478A are located within the West</p>

	<p>Connacht Coast SAC these activities cannot be “Screened Out” and a further assessment is required.</p> <p>Similarly potential impacts on out migrating smolts from Mweelrea/Sheeffry/Erriff Complex SAC arising from aquaculture activity at the salmon cages at licenced Sites T09/143 and T09/143A in the area cannot be “Screened Out” and a further assessment is required.</p>
Who carried out the assessment?	Marine Institute, February 2019

**Figure 1.** Location of licenced aquaculture sites and aquaculture licence application sites in the Killary Harbour area and adjacent Natura 2000 sites.



# UISCE Report for DAFF on Killary Harbour

August 2010



Prepared by the Aquaculture Technical Section, BIM.



## **Reports Main Authors**

Ben Dallaghan and Terence O'Carroll.

## **UISCE Project Partners**

Bord Iascaigh Mhara (BIM), MarCon Computations International, Longline Environmental, Blue Hill Hydraulics Incorporated, Plymouth Marine Laboratory (PML), Pemaquid Mussel Farms (PMF), National Oceanic and Atmosphere Administration (NOAA), Aqua-Fact International Services, Compass Infomatics, Martin Ryan Institute (MRI) and National University of Ireland, Galway (NUIG).

## **Killary Field Work 2007/2008**

Connor Ryan, Niall O'Boyle and Fergal Guilfoyle.

## **Killary Field Work 2009/2010**

Mary Hannan and Pete Donlon.

## **Table of Contents.**

Authors and Project Partners.	2
List of Figures.	3
List of Tables.	3
Background to Report.	4
Introduction to UISCE.	4
Models: Individual shellfish growth.	5
Farm scale.	6
Bay scale.	6
Flow through structures.	6
UISCE - The sampling program, applications and shellfish growth experiments relating to Killary Harbour.	7
Growth experiments.	7
Standing stock assessment.	7
Model applications.	7
Monitoring of mussel growth.	16
Discussion.	22
Recommendations.	23

### List of Figures.

Figure 1.	UISCE hydrodynamic model showing a tidal flow simulation for the whole bay.	8
Figure 2.	Ebb tidal flow for Middle Killary.	8
Figure 3.	Flood tidal flow for Middle Killary.	9
Figure 4.	Modelled chlorophyll distribution in Killary Harbour.	9
Figure 5.	ShellSIM prediction for areas of growth potential in an 'empty' Killary Harbour.	10
Figure 6.	The main input screen displayed in respect of the structure flow model for longlines.	11
Figure 7.	Flow Velocity Contours with lines at 0° to water flow.	12
Figure 8.	Flow Velocity Contours with lines at 45° to water flow.	12
Figure 9.	Food Concentration with lines oriented at 0° to flow.	13
Figure 10.	Indication of Buffer Zone for Site 6 with lines at 0° to flow.	13
Figure 11.	Map of Killary Harbour showing the partitions for ECOWIN.	14
Figure 12.	Input screen for ECOWIN relating to densities of mussels.	15
Figure 13.	Input screen for ECOWIN showing other variables.	15
Figure 14.	Output screen for ECOWIN showing production output after 5 years once a steady state is achieved.	16
Figure 15.	Length of seed mussel at a depth of 5m at sites in Killary Harbour over a year.	17
Figure 16.	Length of half grown mussels at a depth of 5m at sites in Killary Harbour over a year.	17
Figure 17.	Mussel biomass per metre of drop rope (dropper) in the Outer Killary from 2007/2008.	18
Figure 18.	Mussel biomass per metre of drop rope (dropper) in the Middle Killary from 2007/2008.	18

### List of Tables.

Table 1.	Model summary table.	5
Table 2.	Chlorophyll levels as sampled within the mussel farms in Killary on two sampling days.	10
Table 3.	Summary outputs for varying relative densities on longlines (Site 6) with lines at 0° angle to tidal flow.	14
Table 4.	Comparison of the number of drop ropes (droppers) in Outer, Middle and Inner Killary along with the percentage changes if they reduced to 800/Ha.	19
Table 5.	Comparison of current floatation to a limit of 18,000 L/Ha in the various areas of Killary.	20
Table 6.	Comparison of current tonnage and calculated tonnages using limits of 18,000 L/Ha and 800 droppers/Ha.	20
Table 7.	Number of longlines that are either completely or partially outside the current relevant licence areas.	21
Table 8.	Predicted harvest tonnage output from Ecowin relating to thinning and not thinning at current and reduced dropper density.	21
Table 9.	Current average stock and harvest of mussels per Hectare in Killary Harbour.	21

## **Background to Report.**

Prior to the current round of aquaculture licence renewals in Killary Harbour for mussels, the Department of Agriculture, Fisheries and Food (DAFF) requested that Bord Iascaigh Mhara (BIM) analyse the situation in the harbour in respect of various aquaculture and water quality scenarios and questions using the UISCE system. Following on from this BIM was asked to advise the DAFF by making recommendations on how the various issues relating to aquaculture production in the harbour could be resolved and more specifically what issues could be improved by the licensing process.

As part of the process, BIM has looked at the current shellfish stocks and stocking densities within the bay and compared this to the stocks in 2007 along with the position of longlines, number of barrels (litres of floatation) and length and number of droppers. Production methods and mussel growth rates have also been analysed.

## **Introduction to UISCE.**

The main goal of the UISCE (Understanding Irish Shellfish Culture Environments) project was to develop a desktop computer system to allow end users run aquaculture and water quality scenarios in order to get a scientific estimate of the production potential for a shellfish producing farm or bay.

UISCE is more than just a carrying capacity project. It is unique in trying to incorporate various models into one computer application. It must be remembered that at present it is only phase one of a multiphase larger programme that hasn't yet been realized. The project was highly developmental and explorative as it looked at three types of growing methods – rope culture and bottom culture of mussels as well as trestle culture of oysters - in three types of bay systems – Fjord, (Killary Harbour), shallow estuary (Wexford Harbour) and open bay (Dungarvan Harbour). Overall the project was successful. However it did highlight limitations and problems with the current state of certain models and other components which had originally been planned to be enhanced in later phases.

The UISCE system provides a decision support capability to the shellfish farming industries and the regulator and by using this system, for example, one can explore the production potential for a new aquaculture licence application within a bay. It should be noted that predictive output from UISCE scenario runs is only one step in the decision making process. Other factors such as legislative and business environment concerns are ignored by the system. Other points to note are that shellfish growing bays are natural systems and productivity varies year on year. Also, husbandry techniques such as seed thinning have a big impact on the productivity potential of farms and bays. Implementation of this aspect is down to farmers themselves and a coordinated approach to the management of aquaculture within the bay is equally important. This system can help growers and the regulator move away from trial and error aquaculture towards a more scientifically informed decision making process.

The UISCE system is made up of an application layer designed to address industry/regulatory questions, a second model layer which incorporates scientifically developed models that calculate the effect of changes in stocking density and water quality parameters on aquaculture and finally, the data layer which is used to validate models.

The applications graphical user interface (GUI) was developed within a GIS (Geographical Information System) environment which means that users can visualize aquaculture scenarios on screen using familiar map backgrounds with thematic screens and tables being overlaid. The scenarios that are catered for by the application relate to the following broad areas:-

- A. Optimal usage of shellfish stock at farm and bay scales. Seed stocking density scenarios are central to this.
- B. Optimization of husbandry techniques and best deployment of aquaculture structures at farm scale. For example, potential productivity impact of an increase or decrease in the number of aquaculture structures within a bay.
- C. Water quality considerations at bay and farm scale: For example, the identification of sources and causes of poor water quality as well as the impact of changes in water quality on shellfish growth.

### **Models.**

As mentioned above, the system uses different models in order to simulate the shellfish aquaculture growing environment. Everything from water flow to bay scale ecology has to be modeled in order to simulate shellfish aquaculture. Models were supplied by scientific project partners and these models were integrated into the UISCE GIS environment. Table 1 is a summary of the models used by the system. Where applicable these models have been calibrated for use in Killary Harbour. In general, more than one model is required in order to answer a particular question. The integration of models within a GIS frame-work and the construction of a mechanism whereby models could communicate or 'talk' to each other was one of the project cornerstones. To put it simply, the output from one model may form the input to another. For example, the water quality models provide the boundary conditions to drive the aquaculture models.

**Table 1. Model summary table.**

<b>Model Category</b>	<b>Model name</b>	<b>Scale</b>
Physical flow & Water Quality	POM (3D); DIVAST (2D);	Bay and site scale predictions
Physical flow	FLOW-3D;	Structure scale simulation
Biological & Shellfish growth models	MUSMOD; ShellSIM	Individual shellfish growth modelling
Aquaculture site model	FARM Model; MUSMOD	Site scale models
Ecological modelling	ECOWIN 2000 (E2K)	Bay scale ecological model

Two demonstration models of UISCE are available for viewing at the following web addresses [www.marcon.ie/website/html/UISCE\\_walkthrough.php](http://www.marcon.ie/website/html/UISCE_walkthrough.php) and [www.marcon.ie/website/html/ShellSIM\\_walkthrough.php](http://www.marcon.ie/website/html/ShellSIM_walkthrough.php)

### **Individual shellfish growth.**

ShellSIM is our individual growth model. It simulates putting an individual mussel into the sea at a particular place, and modelling its growth. The water quality



parameters that drive shellfish growth vary from one part of the bay to the next. Therefore, the shellfish growth for our hypothetical mussel will also vary. ShellSIM was developed by PML in the UK and this model gives us a theoretical indication of shellfish growth potential within the bay. It should be noted that ShellSIM ignores farm scale considerations such as the proximity of adjacent farms and does not take into account competition from other mussels.

**Farm scale.**

The aptly named FARM model was supplied by the IMAR Institute in Portugal. This model simulates the real world of shellfish aquaculture i.e. where shellfish competition for resources due to stocking density is an issue. Population dynamics, density related competition, mortality and site specific water quality are the main driver variables for this model. The FARM model allows for the rapid assessment of an individual farm within a bay. Estimates for multiple farms and 'aquaculture overcrowding' are not catered for by this model. However, using our knowledge of flow and food reduction as water percolates through several mussel farms does allow us to fine tune farm scale simulations as one can edit the model inputs based on actual data and expertise developed on the project. These take time to set up due to the complexity of the task involved. Certain limitations of this model have been encountered and modifications are required subject to further funding being available. This is similar to the life cycle of any software application where we envisage various version releases of the UISCE software, i.e. release 1.0, 2.0 etc. where the accuracy of model output increases as expertise and hard data accumulate.

We did try to use another 'farm scale' model called MUSMOD. However, the model version supplied is problematic and needs further revision and improvement.

**Bay scale.**

Bay scale changes in aquaculture can be simulated using the ECOWIN 2000 model (supplied by the IMAR Institute). For example, changes in the overall shellfish stocking levels for a bay can be explored using this model. This model works well when compared to hard data and production figures.

**Flow through structures.**

The most likely scenarios for the flow of water through both longlines and trestles were developed using FLOW-3D by Blue Hill Hydraulics Ltd. This model shows water current changes and depletion of phytoplankton as they pass through the structures.

## **UISCE - The sampling program, applications of models and shellfish growth experiments relating to Killary Harbour.**

In order to develop working models for Killary we had to set up a sampling program to get 'real' data for model calibration purposes. There were two aspects to this program:-

1. Water quality sampling.
2. Shellfish growth experiments.

All shellfish growth drivers were recorded using a variety of equipment deployed within the bay. Water flow, temperature, salinity, and other biogeochemical parameters as well as shellfish growth measurements were recorded. If you know how fast a mussel grows in a particular part of the bay, then you can use this data to check the accuracy of your predictive models.

### **Growth experiments.**

Shellfish growth experiments were conducted whereby mussel lines were observed over a number of years. Growth rates on the lines for 'near channel' and 'near shore' were recorded for different parts of the bay. These test sites allowed us to determine what is really happening in Killary and these datasets constitute the project 'hard data'.

### **Standing stock assessment.**

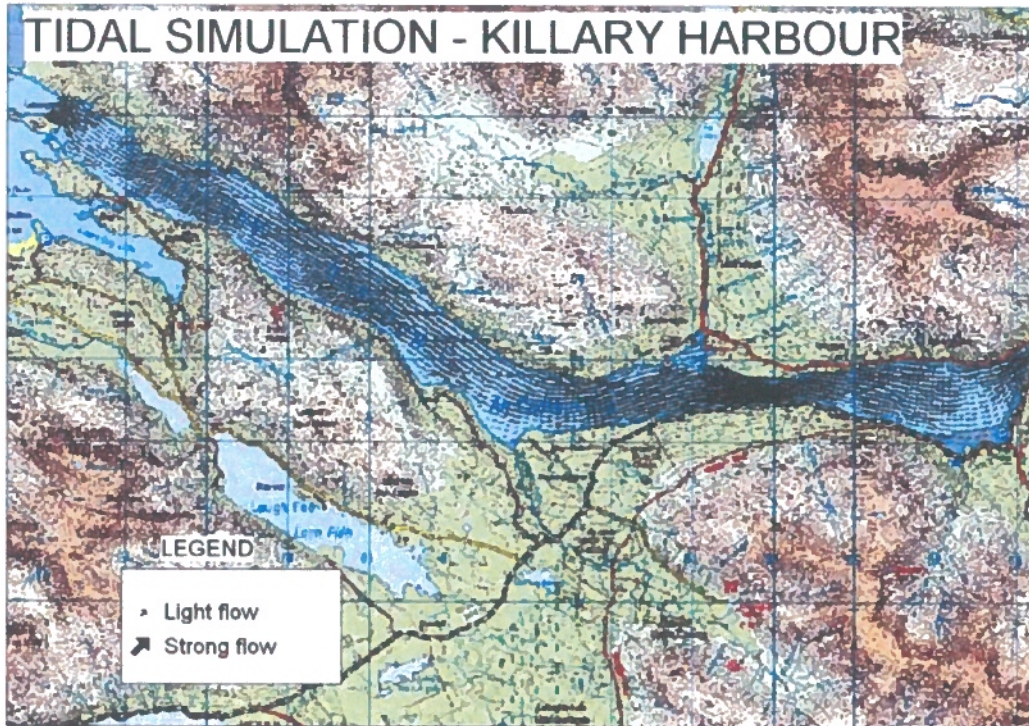
Before embarking on the project it was recognised that an accurate picture as to the quantity of shellfish within Killary was required. These estimates give us our standing stock figures. To this end, shellfish 'standing stocks' were assessed twice, in 2007 and 2009/10. The location and stocking level for each mussel line was recorded and this information can be used in updating and running the UISCE system.

### **Model applications.**

Another use of the UISCE system is to explore the main water quality drivers of mussel growth which are water '*flow*' rates and '*food*' (chlorophyll relating to algae/phytoplankton) distribution patterns.

Figure 1 represents the output from the UISCE hydrodynamic model showing a tidal simulation for the whole bay. In this particular figure the magnification is low and the tidal arrows are hard to distinguish, the darker areas represent stronger flows. One can see that the tidal flow is strongest where the bay is narrow. It should be noted that this component model does not take into account the structures in the bay and how they affect the flow (this is dealt with later).

Figure 1. UISCE hydrodynamic model showing a tidal flow simulation for the whole bay.



The following map, Figure 2, represents the output from the model run for an ebb tidal flow within middle Killary. One can see areas to the south which have reduced flow when compared to the main channel.

Figure 2. Ebb tidal flow for Middle Killary.

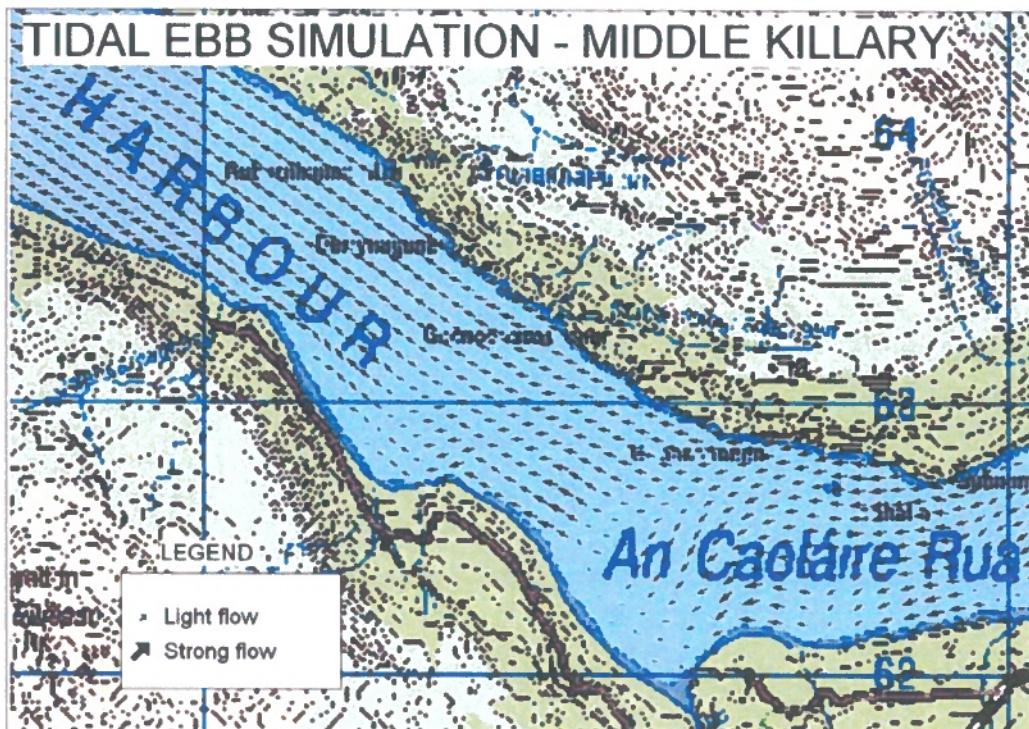


Figure 3 represents output for a flooding tide within middle Killary. Similarly to the ebb flow, one can see areas to the south of the bay which have reduced flow when compared to the main channel.

Figure 3. Flood tidal flow for Middle Killary.

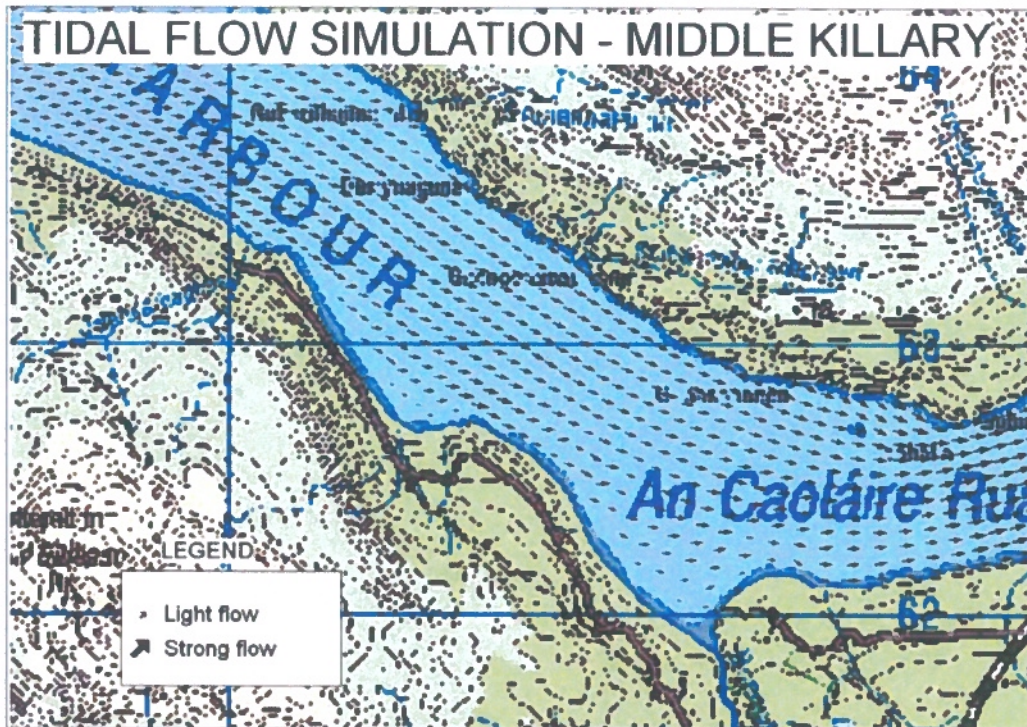
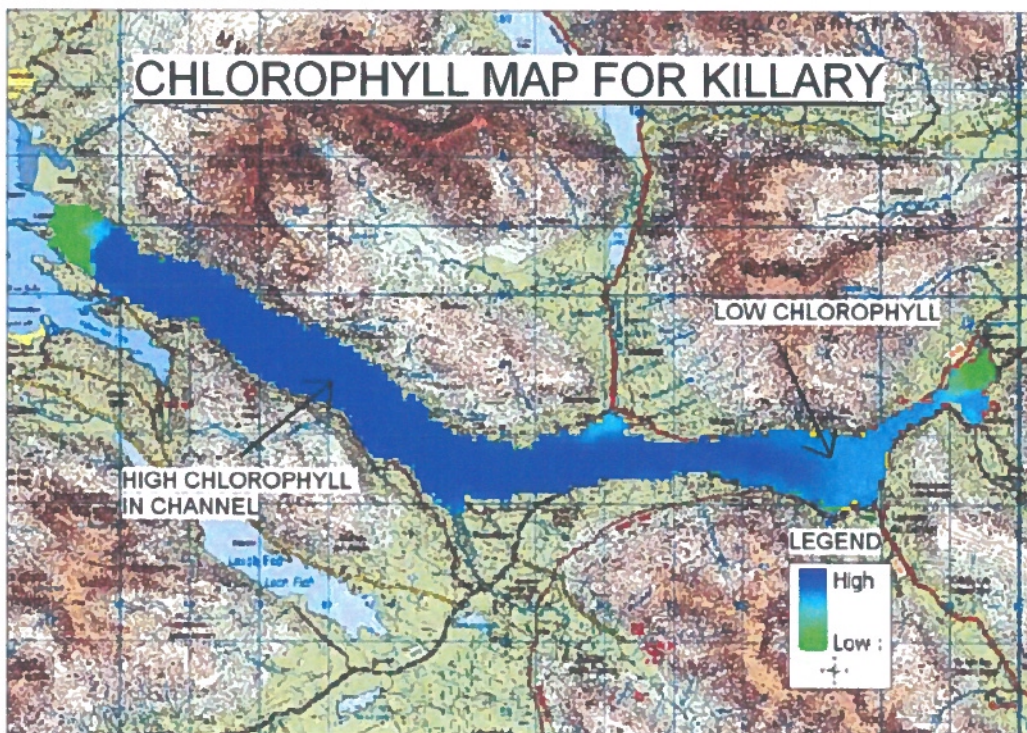


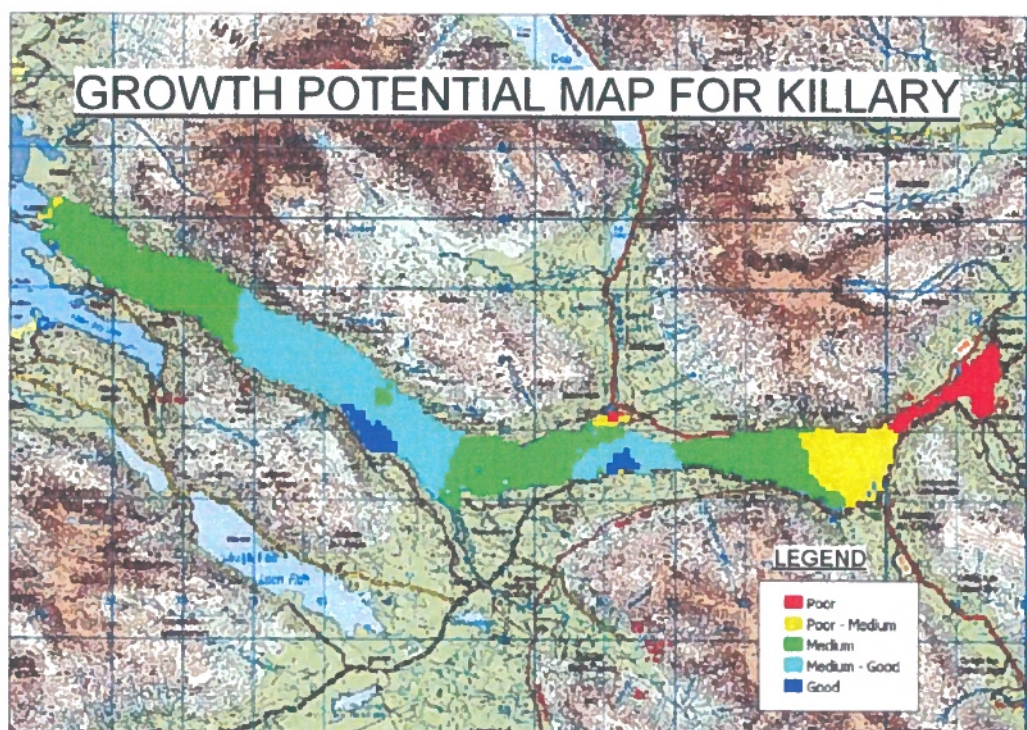
Figure 4. Modelled chlorophyll distribution in Killary Harbour.



The chlorophyll map, Figure 4, shows simulated spatial variation of chlorophyll throughout the harbour. Chlorophyll is found in algae/phytoplankton which is a food source for mussels, so by measuring a type of chlorophyll (chlorophyll a) we can get a good indication as to how much food is available. This information, combined with an understanding of bay hydrodynamics can help us predict where the best potential growth can be found.

Figure 5 depicts the cumulative result of ShellsIM simulations whereby mussel growth is predicted for all parts of the bay. This assumes there are no farms in the bay. It is interesting to note that the first mussel farms established in the bay were in good growth areas as depicted in Figure 5. However due to increased farming activity these areas (especially the Middle Killary) are now showing poor growth performance.

**Figure 5. ShellsIM prediction for areas of growth potential in an ‘empty’ Killary Harbour.**



During the course of the field work for the project the sampling profiles indicated a significant reduction in chlorophyll concentration in the mussel farming zone on the southern side of the bay when compared with the channel or elsewhere.

**Table 2. Chlorophyll levels as sampled within the mussel farms in Killary on two sampling days.**

Sample date	Chlorophyll analysis	Micrograms / L
25/07/2007	Middle -Channel	0.78
25/07/2007	Middle - Shore	0.72
09/08/2007	Middle -Channel	1.13
09/08/2007	Middle - Shore	0.93

By looking at the sampling data for chlorophyll one can see that the general trend is for chlorophyll to reduce as one moves from the channel towards the shore through the farms.

Carter Newel (PMF) analysed this data and his findings are summarized as follows:- Sampling profiles indicate a reduction in *chlorophyll a* concentration of about 50% in the mussel farming zone on the southern side of the bay when compared with the channel or elsewhere. Further reductions of 8-20% of *chlorophyll a* were noted inside double long lines and between them.

The Flow-3D model has been set up to simulate a series of conditions in relation to flow through the longline structures in Killary Harbour for specific sites with a defined number and length of longline. The model permits an incremental increase or decrease in relative density (i.e. how many mussels on a line which relates to the thickness of the mussel drop ropes) and a change in orientation to the tidal flow for the longlines.

Figure 6 below shows the standard longline input screen with Figures 7 and 8 showing the velocity contours for the tidal flow at 0° and 45° to the orientation of the longlines. From the various analysis completed it is found that the current orientation of the longlines is fairly optimal and there would be no improvement in growth etc. by changing their orientation. What is apparent though is that if the length of longline head rope is increased this would impact on the growth rates in the middle of the lines. Figure 9 show significant reduction in food concentration after about 30m along the line but it should be realised that this will be reversed when the tide changes direction as the other end of the line will now receive the bulk of the food. So it is the middle area that has the potential to be impacted.

**Figure 6. The main input screen displayed in respect of the structure flow model for longlines.**

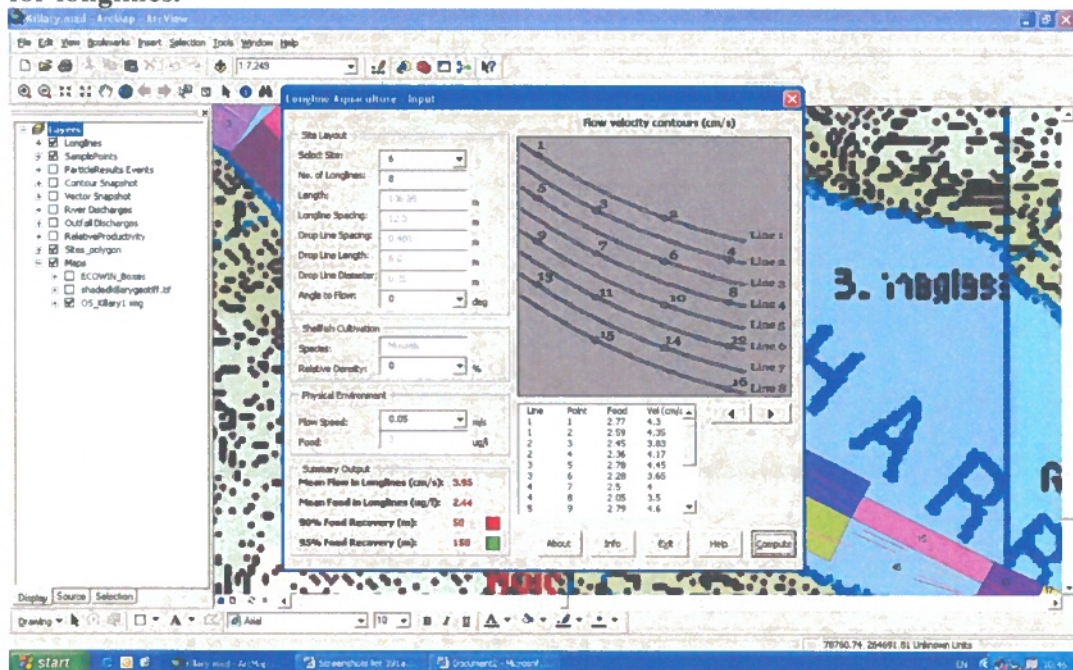


Figure 7. Flow Velocity Contours with lines at 0° to water flow.

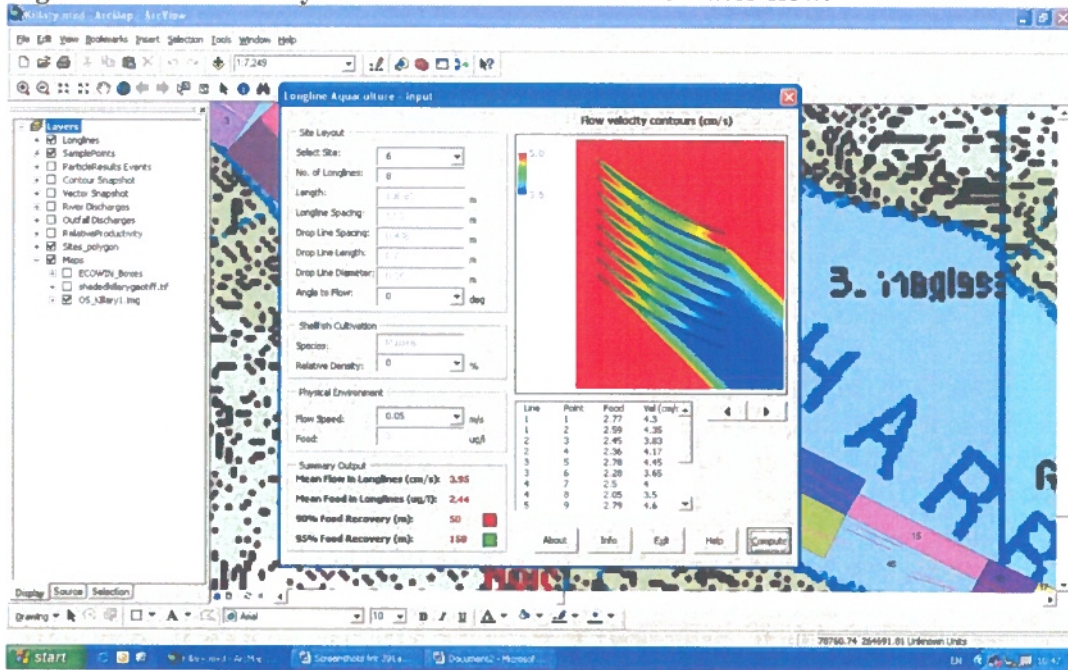
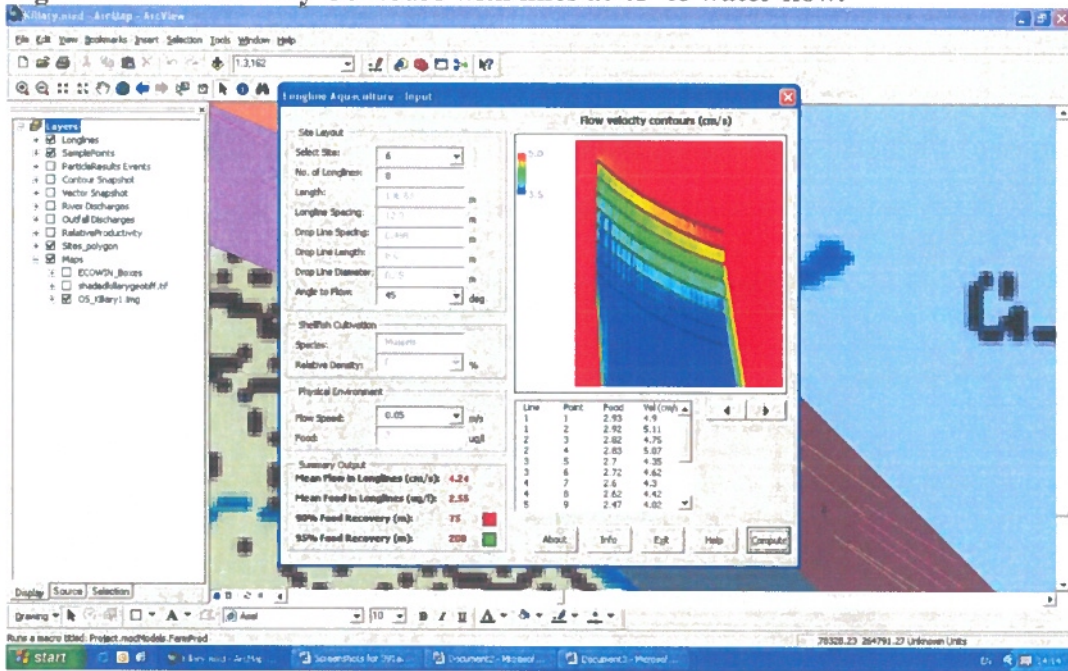
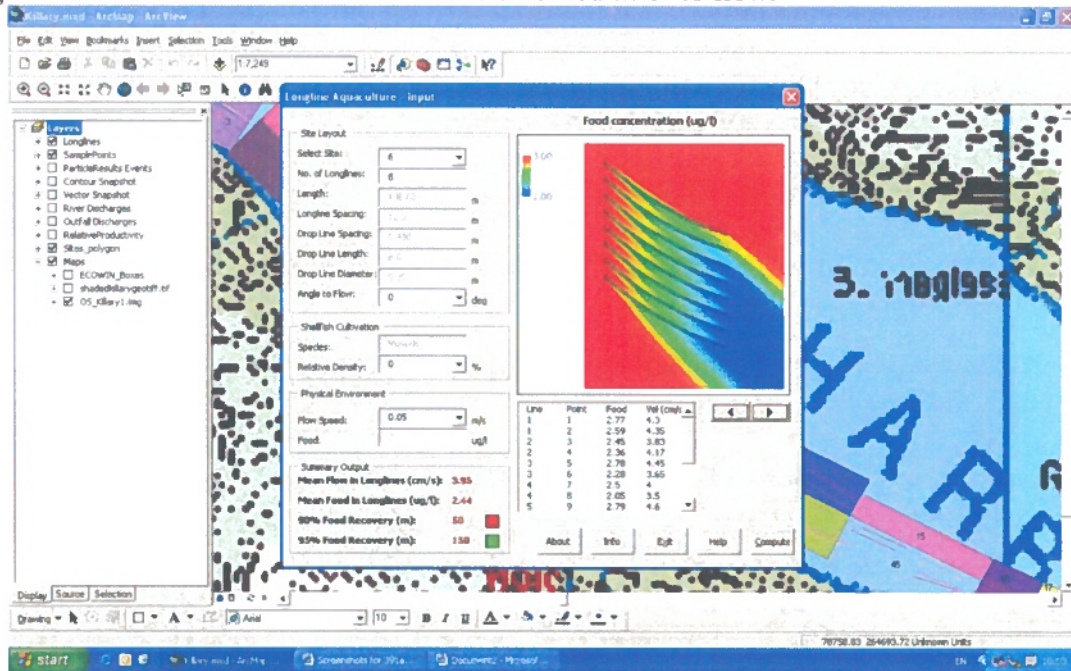


Figure 8. Flow Velocity Contours with lines at 45° to water flow.

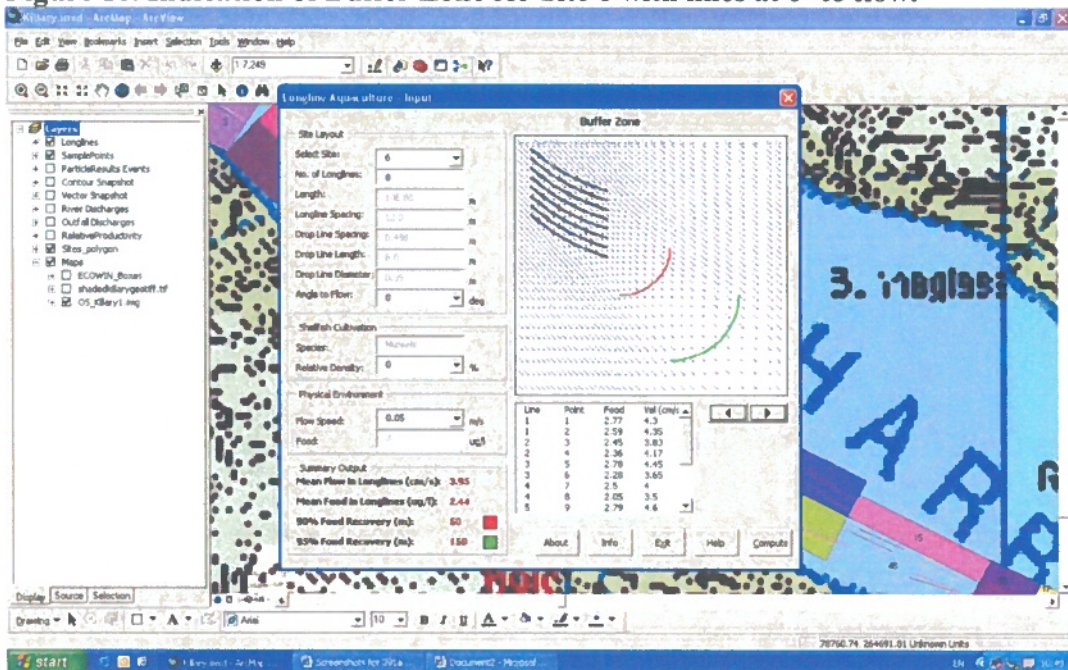


**Figure 9. Food Concentration with lines oriented at 0° to flow.**



One of the most important results from this model is the ability to predict the buffer zone i.e. how far after the water has flowed through a mussel line will it be before the food levels return to near what they were on entering the line. In general in Killary after 50m there is a 90% recovery and after 100 to 150m there is nearly a 95% recovery (see Figure 10). The implication of this for the management of the bay is that the spacings proposed between blocks of longlines once the anchors etc. are back within the licensed sites will be beneficial as it will open up channels that will help the flow of water and hence food recovery between the lines.

**Figure 10. Indication of Buffer Zone for Site 6 with lines at 0° to flow.**





On development UISCE used the positions of lines and standing stocks as of 2007 in developing the “plots or sites” for the farm model. It was important that the lines were contained within the boundaries of the sites, so in many cases these sites do not match up exactly with licence boundaries. So Site 6 referenced above refers to a specific block of lines and not a specific licence.

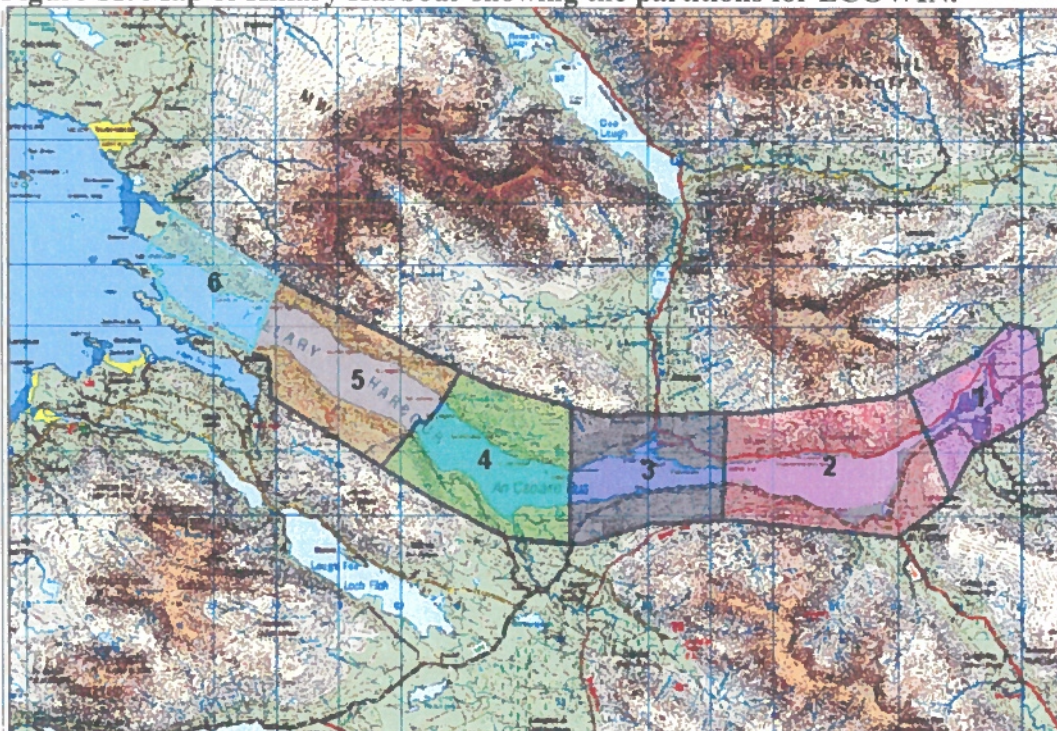
Table 3 shows that if you reduce the physical relative stocking density on the line (i.e. reduce number of droppers) then the recovery of the food source happens in a shorter distance which would again be beneficial to neighbouring sites to help improve growth rates etc.

**Table 3. Summary outputs for varying relative densities on longlines (Site 6) with lines at 0° angle to tidal flow.**

Relative Density %	Mean Flow (cm/s)	Mean Food (µg/l)	90% food recovery (m)	95% food recovery (m)
0	3.95	2.44	50	100
+25	3.73	2.31	125	200
+50	3.53	2.19	150	200
-25	4.16	2.57	20	100
-50	4.42	2.71	20	20

The bay scale carrying capacity model ECOWIN works by dividing the bay into sections (see Figure 11). In Killary the bay is divided into 6 sections along the bay and at two depths giving 12 boxes in all.

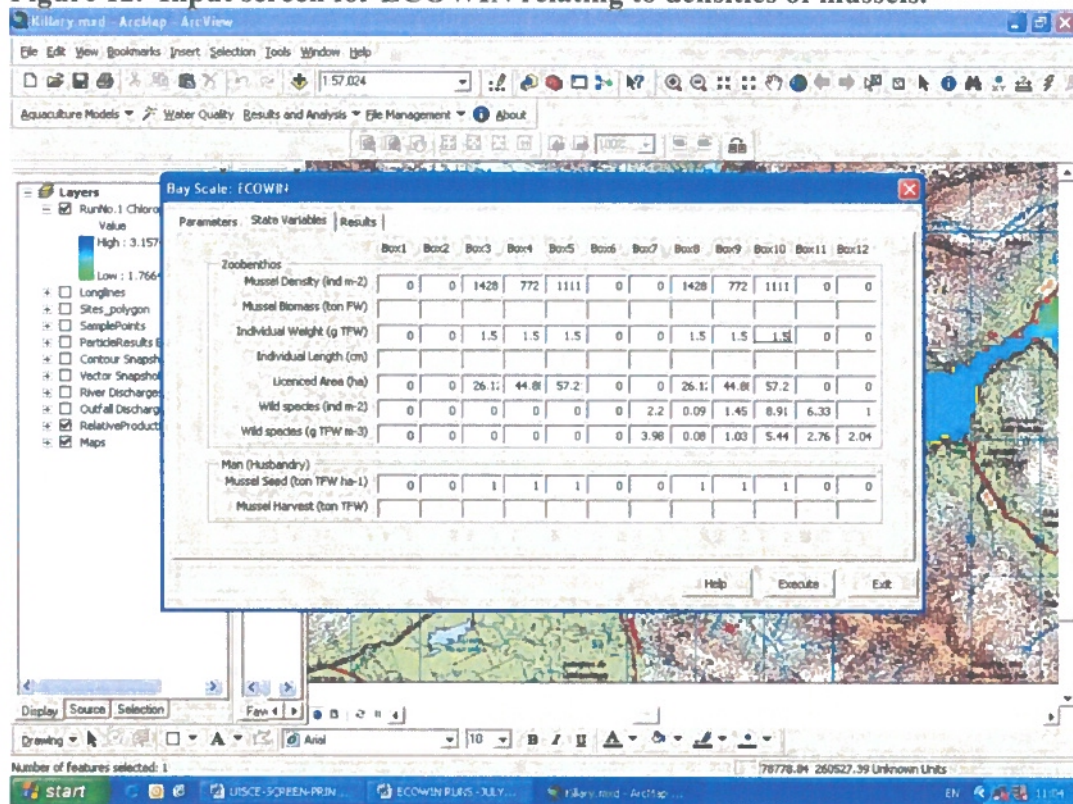
**Figure 11. Map of Killary Harbour showing the partitions for ECOWIN.**



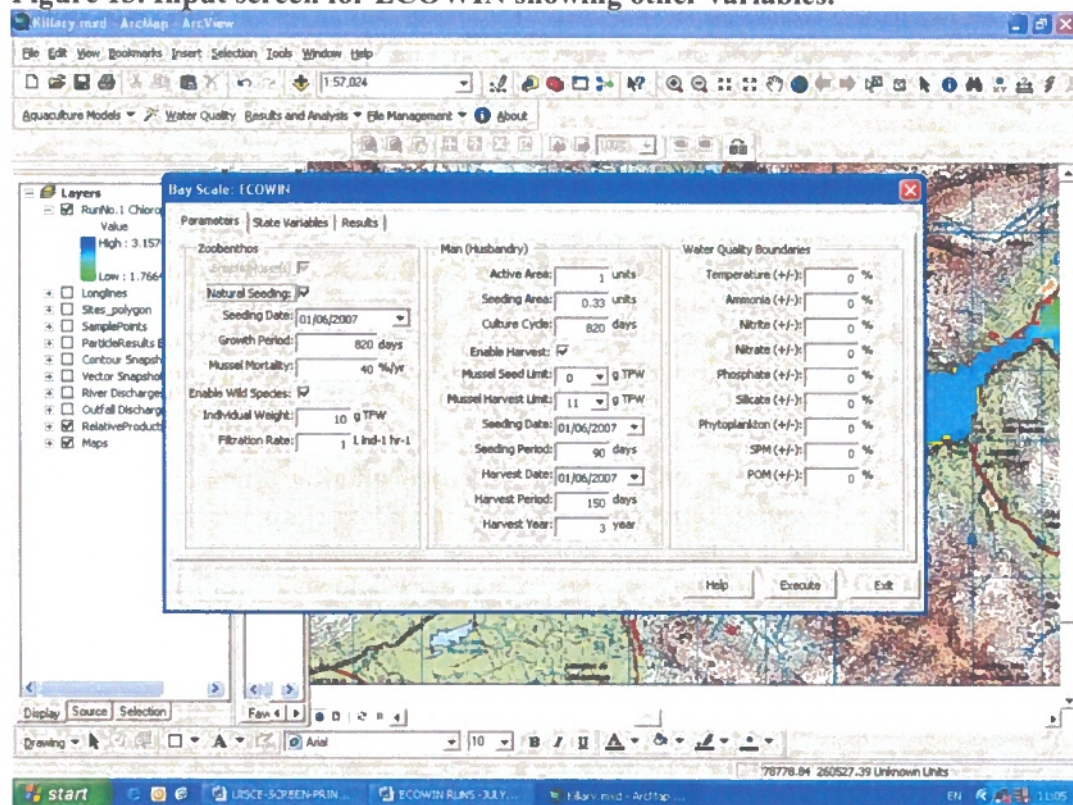
Using the UISCE application we can vary the amount of mussels, mortality etc. in

these boxes (as seen in Figure 12 and 13) and run various scenarios with ECOWIN.

**Figure 12. Input screen for ECOWIN relating to densities of mussels.**

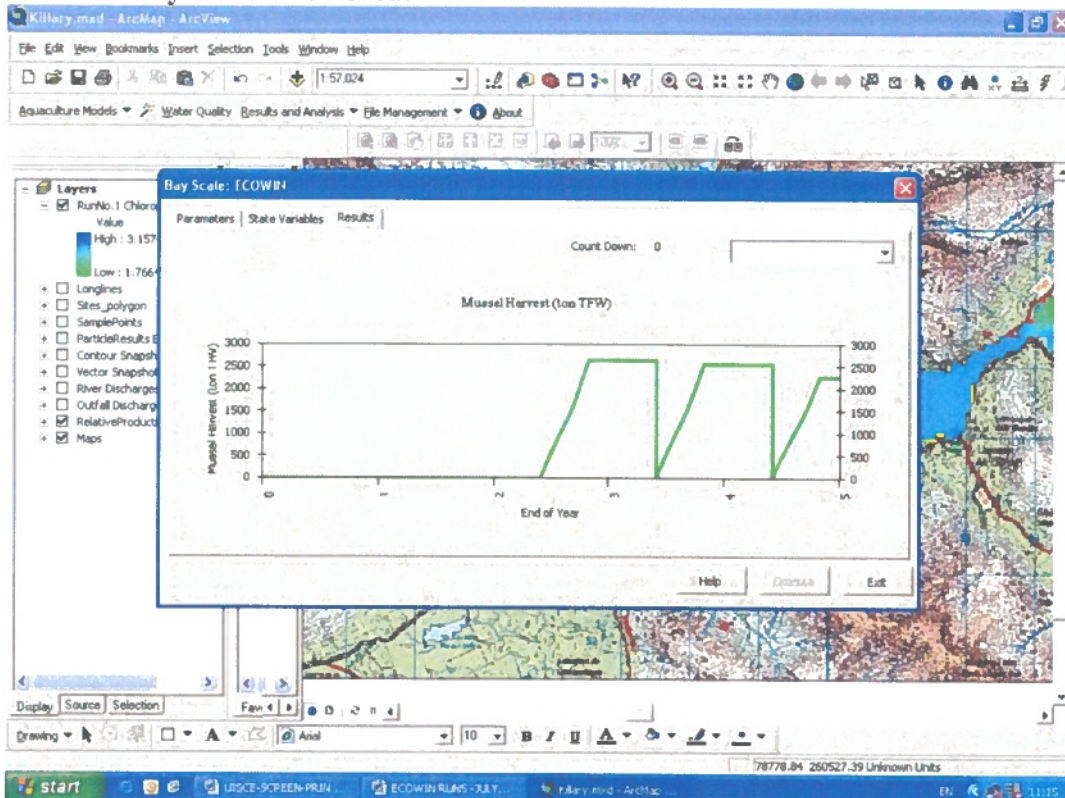


**Figure 13. Input screen for ECOWIN showing other variables.**



Mortality refers to mussels dying from such things as drop off and predation etc. Figure 14 illustrates an output screen for one such run.

**Figure 14. Output screen for ECOWIN showing production output after 5 years once a steady state is achieved.**



Using 2007 stock data ECOWIN predicted an annual harvest of 1,820 tonnes based on a standing stock of 3,925 tonnes. More results from the ECOWIN model are discussed later.

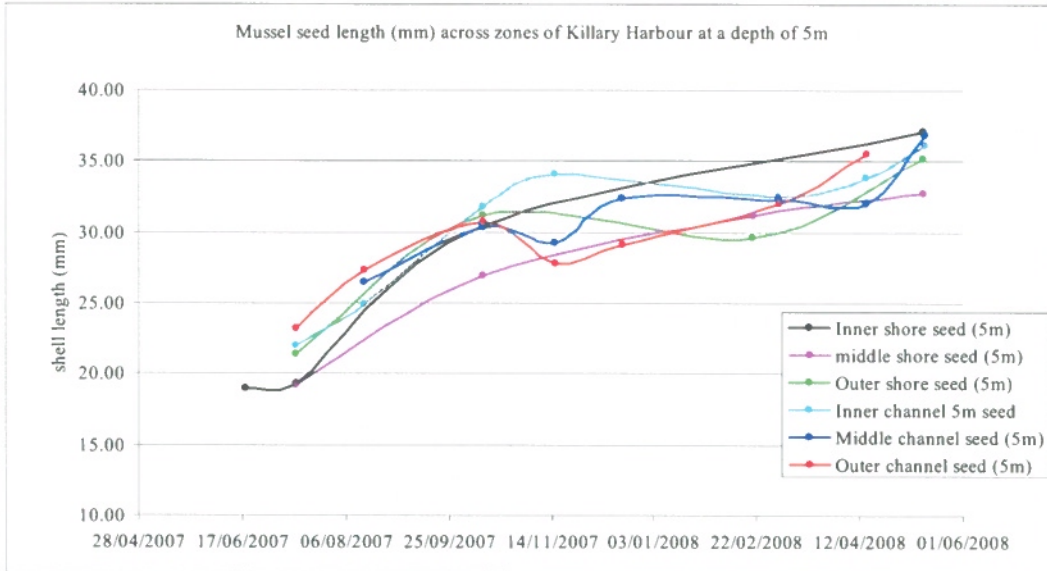
### Monitoring of mussel growth.

During the course of the UISCE project various sites in Killary Harbour were monitored for mussel growth. Six main sample points were selected corresponding to mussel lines in Outer, Middle and Inner Killary with a sample point on the outer edge of a farm near the channel (northern edge of farm) and a sample point on the southern edge of a farm near the shore. Both seed and half grown mussels were monitored at depths of 1m and 5 m.

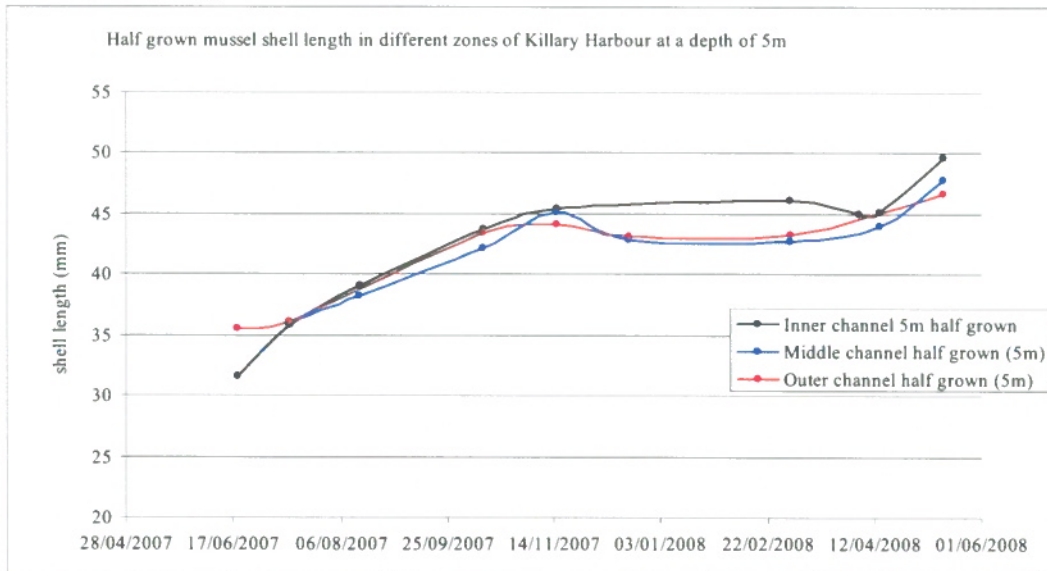
Figures 15 and 16 show the growth of mussel seed and half grown mussels respectively over a 12 month period at the six sites in Killary Harbour. You will note that in many of the sample points there is a decrease in measured size of mussels over the Winter period. This is primarily because of a process known as 'drop off'. In previous studies carried out by BIM a net was placed under mussel ropes on the long lines and it was found that the larger mussels tended to grow and move to the outside of the rope. During storm events these mussels were shaken off and fell to the bottom. This results in an apparent decrease in the mussel size and weight per metre when a sample was measured from the mussel rope. This process is more pronounced in exposed areas and is exacerbated when there is an excess of floatation and a wide

variation in mussel size on the rope. From the graphs it is seen that the inner harbour has the best growth rate. This is more likely due to the site being more sheltered than anything else.

**Figure 15. Length of seed mussel at a depth of 5m at sites in Killary Harbour over a year.**



**Figure 16. Length of half grown mussels at a depth of 5m at sites in Killary Harbour over a year.**

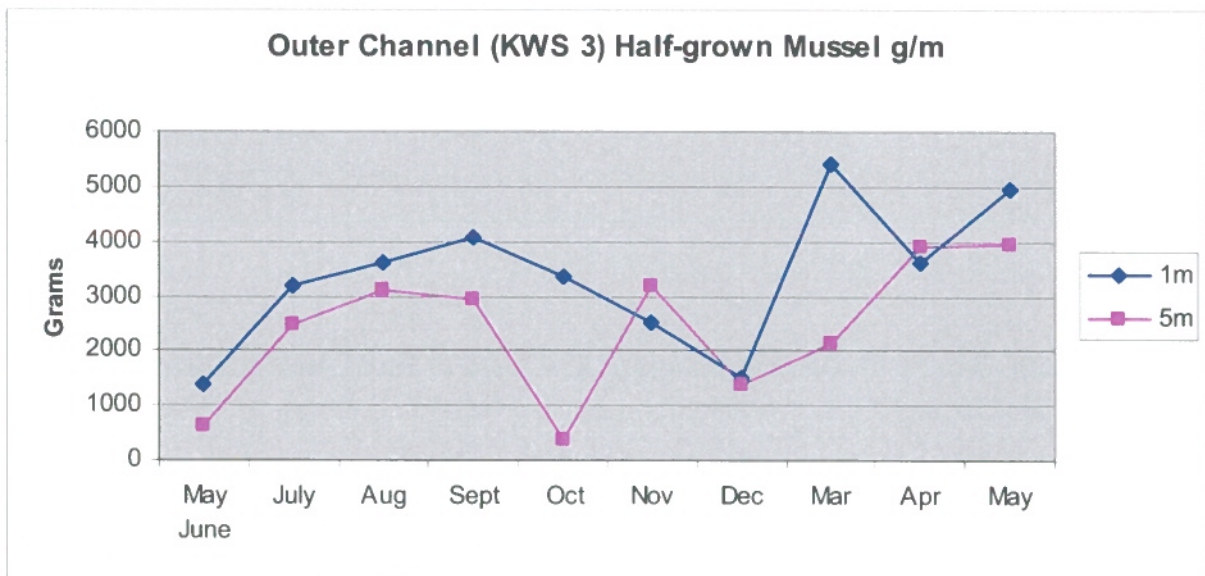


Rather than supporting the local perception that the outer sites are better sites, the above graphs indicate that the growth in all sites is rather poor. Figures 17 and 18 give a better indication of what is happening.

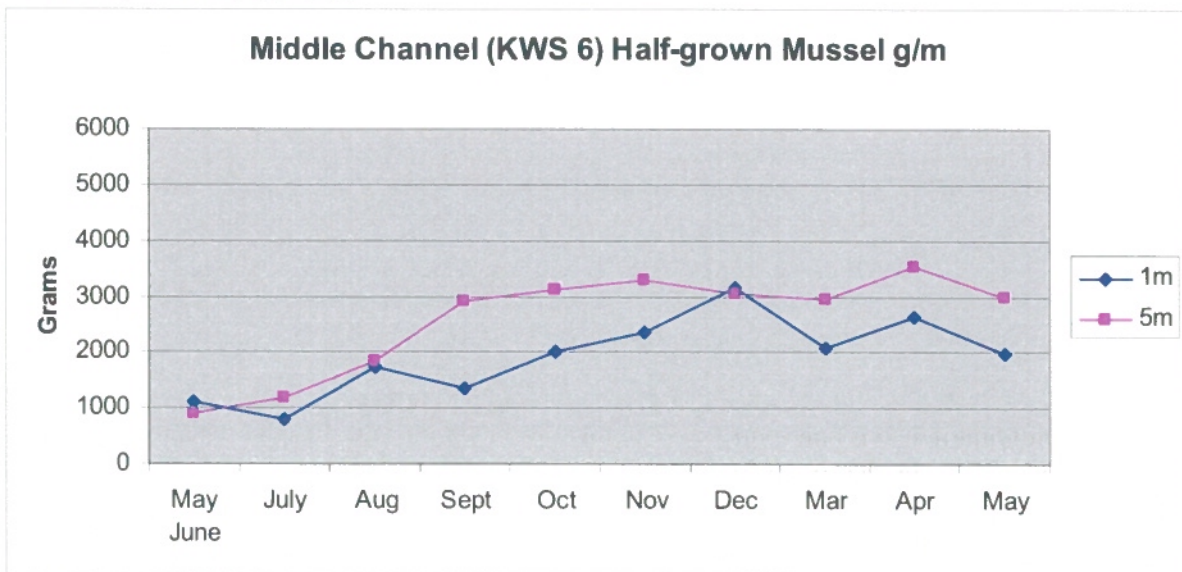
The basic structure that the mussels cling onto is the drop rope (this can be pergolari, collector mesh or rope). These ropes when relatively full hold approximately 5Kg. of

mussels per metre. This is due to physical limitations as much as biological conditions and relates to the diameter of mussels on the rope and how they can attach firmly back to the rope or support material. What is seen from the graphs is that the biomass reaches around 4 Kg/m in the Outer harbour and 3 Kg/m in the Middle harbour and then levels off. This is related to the biomass that can be supported, given the current husbandry practices, at these particular sites. So, as we have seen previously, if the mussels are growing yet the overall biomass is the same (apart from storm associated drop off) then what is happening is that mussels are reducing in number per metre. This means there is competition for space and food between the mussels on the drop rope and that certain mussels are growing and dropping off while others are being smothered and die leaving the rest to grow.

**Figure 17. Mussel biomass per metre of drop rope (dropper) in the Outer Killary from 2007/2008.**



**Figure 18. Mussel biomass per metre of drop rope (dropper) in the Middle Killary from 2007/2008.**



Generally seed mussels in Killary are obtained by putting out collection ropes onto which the naturally occurring mussel larvae in the water will settle. This settlement can vary from year to year and some years there can be several settlements of mussels. This affects the density of the mussels on the drop ropes. From measurements during the course of the UISCE project and last Winter, settlement number can easily range from 2,500 to 5,000 mussels per meter. In Killary the predominant culture practice is to leave the mussels on the collectors until they reach marketable size, usually around 10-12g and 45 to 60mm (though some limited thinning, stripping and repacking does take place). The culture ropes can only hold a certain amount or biomass of mussels, in Killary this is around 5Kg per metre. When the mussels are ready to harvest you would normally have around 450-550 10g mussels per metre. This means if there was 2,500 mussel per metre to start with and you end up with 500 then you have had a mortality of 80%. If you had a better settlement then the final mortality will be even higher. Therefore it is apparent that the biggest factors affecting growth rates and production etc. in Killary Harbour is the density and mortality of mussels per metre.

Using the latest longline equipment and stock survey from the Winter of 2009/2010 various analyses have been completed. The bay has been divided into three main sections relating to the current farming areas of Outer, Middle and Inner Killary. The question of the number of drop ropes has arisen in discussions with various growers and a suggestion was put forward by the Killary CLAMS group on what would be the impact of reducing the number of 8m droppers to 800 per Hectare along with limiting the floatation on the licences to 18,000 Litres per Hectare. Table 4 breaks down the estimated number of drop ropes (droppers) normally present on the longlines in the various areas along with giving the corresponding number if it was limited to 800/Ha. It can be seen that at present the farms in the Middle Killary are already operating on even less droppers per Hectare where the Outer and Inner Killary sites would have to reduce the droppers by 15% and 34% respectively.

**Table 4. Comparison of the number of drop ropes (droppers) in Outer, Middle and Inner Killary along with the percentage changes if they reduced to 800/Ha.**

	Normal No. droppers	No. Droppers @800/Ha	Over/Under(-)	% Over/Under(-)
<b>Outer</b>	51,013	43,372	7,641	15%
<b>Middle</b>	30,851	38,304	-7,453	-24%
<b>Inner</b>	31,083	20,496	10,587	34%
<b>Totals</b>	112,947	102,172	10,775	9.5%

Table 5 deals with the current level of floatation in the areas and again it is clear that Middle Killary is already operating under the limit of 18,000 L/Ha. Nearly all other growing areas in the country operate at this limit or below. At present Killary Harbour has way over the requirement of floatation to support its existing stocks of mussels.

In Table 6 the total tonnage that the areas could hold (actual surveyed tonnage plus calculated tonnage that would be present if the empty lines on site were full at present stocking levels on the farms) is compared with the tonnage that the current floatation could safely support (2.16 Kg/L). This clearly illustrates that at present Killary

**Table 5. Comparison of current floatation to a limit of 18,000 L/Ha in the various areas of Killary.**

	<b>Current Floatation (L)</b>	<b>At 18,000 L/H</b>	<b>L Over/Under(-)</b>	<b>% L Over/Under(-)</b>
<b>Outer</b>	1,258,080	975,870	282,210	22.4%
<b>Middle</b>	675,170	861,840	-186,670	-27.6%
<b>Inner</b>	684,470	461,160	223,310	32.6%
<b>Totals</b>	2,617,720	2,298,870	318,850	12.2%

Harbour currently has nearly twice as much floatation as required to hold its current stocks. Table 6 also compares the potential tonnage that could be produced if the floatation was limited to 18,000 L/Ha or if limited to 800 droppers/Ha. This excess floatation is one of the reasons that mussels are shaken off the longlines during rough weather conditions and also facilitates the potential for overstocking.

**Table 6. Comparison of current tonnage and calculated tonnages using limits of 18,000 L/Ha and 800 droppers/Ha.**

	<b>Survey Tonnage</b>	<b>Assumed tonnage off empty lines</b>	<b>Total tonnage</b>	<b>Potential tonnage at current floatation</b>	<b>Tonnage at 18,000L/ Ha</b>	<b>Tonnage at 800 droppers/ Ha</b>
<b>Outer</b>	871	430	1,301	2,717	2,108	1,735
<b>Middle</b>	602	318	920	1,458	1,862	1,532
<b>Inner</b>	399	248	647	1,478	996	820
<b>Totals</b>	1,872	996	2,868	5,653	4,966	4,087

It is clear that including licence conditions that have a maximum floatation of 18,000 L/Ha and 800 X 8m droppers will not adversely effect the current overall production in Killary Harbour. Indeed 18,000 L/Ha can be considered an overestimate of floatation given that to hold the existing potential total stock of 2,869 tonnes you would conservatively only need 1,328,356 L of floatation which equates to 10,360 L/Ha.

As has been noted the farmers in Middle Killary have changed their farming practices since 2007 by reducing floatation and numbers of drop ropes per Hectare. Unfortunately as there has not been a corresponding change in the Outer and Inner Harbour there has not been any significant change in production and growth rates in the Middle Harbour.

From the recent surveys carried out the total number of longlines in the bay is 246 along with two rafts. Table 7 details the number of longlines completely outside licence areas, those longlines with their headropes partially outside the areas and those with only the anchors outside. Therefore to comply fully with the licence condition of all longlines including anchors to be within the relevant licensed site then 146 out of 246 lines will have to be moved. If this is done channels will be opened between blocks of longlines which will permit better water flow and as mentioned previously this will result in better recovery of food and should lead to improved growth rates.

**Table 7. Number of longlines that are either completely or partially outside the current relevant licence areas.**

	No. Lines outside licensed sites	No. Lines partially outside	No. Lines with moorings outside
<b>Outer</b>	15	21	15
<b>Middle</b>	6	7*	20
<b>Inner</b>	28	27	7
<b>Totals</b>	49	55*	42

\* Includes 6 lines that straddle licence boundaries which are part of the same company's licences.

By inputting the stock situation as in the Winter of 2009/2010 into ECOWIN it predicts a harvest output of 2,000 tonnes. Note this takes into account the changes that have been made since 2007 primarily in respect of Middle Killary. If we reduce the number of droppers to 800/Ha. then this figure comes out at 1,950 t. In Table 8 the results from various runs of the ECOWIN model are summarised where we compare the current situation in Killary and at the reduced number of droppers along with the practice of thinning the longlines as practiced in other bays.

**Table 8. Predicted harvest tonnage output from ECOWIN relating to thinning and not thinning at current and reduced dropper density.**

Annual Mortality		Output from Existing No. Droppers	Output from Droppers @ 800/Ha
55%	No thinning	2,000 t	1,950 t
40%	Thinned at 1.5g	2,250 t	2,200 t
25%	2 <sup>nd</sup> thinning at 3 <sup>g</sup>	2,350 t	2,300 t

ECOWIN predicts that the tonnage would increase significantly if the practice of thinning and repacking mussels was introduced. What is not initially apparent is that these tonnages would be produced in a quicker time as the mussels would grow faster, within a 2 year period, rather than the current production time of over 2 to 3 years. Shortening the production cycle back to under 2 years is as important as increasing production in the bay as there is less chance of stock loss or fouling along with requiring less growing equipment to produce the same tonnage.

**Table 9. Current average stock and harvest of mussels per Hectare in Killary Harbour.**

	Av. Tot. stock/Ha	Av. Harvest/Ha
<b>Outer</b>	24	13.7
<b>Middle</b>	19.2	11.8
<b>Inner</b>	24.8	9.2
<b>Average</b>	22.4	12.1

For farms in other bays the harvest production per Hectare ranges from 10.6t for areas that do not thin to 16 to 24t for areas that practice thinning.



### **Discussion.**

Once the growth to market size of rope mussels exceeds 2 years this indicates that there are problems with the carrying capacity and the production area is most likely overstocked.

In simple terms the carrying capacity of a bay for a certain species is how much of that species can be sustainably produced in a particular bay. This depends on many factors but simplistically comes down to how much food (phytoplankton) is available. The simplest carrying capacity models assume the food is evenly distributed within the bay along with the shellfish. In reality this distribution of food varies due to many factors such as water flow, nutrient input sources, temperature, weather etc. The shellfish themselves are also not uniformly distributed so that you can have crowding affects similar to keeping sheep in a corner of a field where they will eat all the grass available and yet there would be plenty of grass left in the rest of the field. In addition apart from the cultured shellfish that eat the food you must also take into account the wild stocks present in the bay.

Carrying capacity, biomass and harvestable tonnage are all interrelated with growth rate. Simply, if there are less shellfish in an area they will grow faster as food is not limiting. When you put more shellfish in the system there reaches a point when food does become limiting and the growth rate starts to slow down. If you increase the stock further a plateau is reached where the food has been limited and no further growth is possible unless the number of shellfish is reduced again. In the natural environment this usually leads to starvation and mortalities.

When the stocking density is too high or the carrying capacity of the bay is being reached, one of the first consequences is slower growth i.e. that it then takes two and a half years to reach market size instead of two years. This means that another year class of stock is added to the system thus increasing the biomass further and exacerbating the problem. This process is quite gradual and cumulative taking several years for the initial increase in seed stock to have its effect on the carrying capacity. Then with every subsequent year it can take longer and longer for stock to come to market size. If you add to this prolonged closures due to biotoxins you can very easily reach the situation where you are carrying nearly a third more biomass than in a two year cycle and yet the overall annual harvest increase may be as little as 10%.

Quite often people will say that, at the above stage, the carrying capacity is reached for the bay. This is not quite true. What has happened is the growth rate has slowed but it may still be possible to increase the biomass even further again sacrificing growth rate. What does occur is that it becomes uneconomical to continue to grow mussels at a certain stage. As nearly every site in a bay is different where one farm may be having serious problems, another farm may be performing well due to no fault of either party.

In the situation as it relates to Killary Harbour, unfortunately you can have a farmer that has not changed his practices for years being impacted as a result of another person or an accumulation of several other peoples activities (along with biotoxin closures). At this stage it is very hard to identify one specific reason for the slow

growth problem and come up with an easy solution on how to fix it but it is clear that there is overstocking.

One of the issues relating to structures and mussel growth is the flow of water. The food for the mussels (algae/phytoplankton) is carried in the water, hence if the flow is reduced so too is the amount of water and food delivered to the mussels. So the physical mass of mussels on drop ropes and the number of drop ropes does affect the flow of water through the longlines.

Spacings between longlines and leaving channels between blocks of lines is beneficial. Making farmers move their anchors back into their licensed sites will help the flow and recovery of phytoplankton between blocks of lines. However, if there is no associated reduction in the number of droppers etc. then the potential crowding of the lines into smaller blocks will increase the density of mussels at a local level and will most likely impact on mussel growth and harvest tonnage in those and adjacent sites.

The practice of thinning drop ropes (stripping off mussels and repacking) has the effect of reducing mortalities significantly. As seen above with a relatively low settlement in Killary with no thinning the mortality is at least 80% and up to 95% if there is a heavy settlement, whereas with thinning the mortality only ranges from 25% to 40%. Why this is important is that all the mussels that eventually die or drop off the lines have been feeding and taking up space and thereby increasing the competition for food etc. with the mussels that will be eventually harvested.

One of the main reasons given for not thinning mussels is the increased cost of stripping and repacking. Realistically though, if this is analyzed from an economic point of view you will find this labour and equipment cost is offset by not having to have at least a third more longlines for an extra year class when you do not thin, along with having a shorter growth cycle which decreases the risk of fouling and secondary settlements etc. This ultimately results in harvesting more tonnage per Hectare on an annual basis. The main problem though is for thinning to be most beneficial nearly everyone in the bay would have to adopt the practice in order to help reduce the biomass and density of mussels in the bay.

Another way of addressing this issue of high mortalities is to try and collect the correct amount of seed per metre on the collectors originally. This has been quite successfully done in Ardroom where, though the yield per Hectare is lower than in areas that thin, the growth rate is comparable and the crop is harvested within a two year cycle.

#### **Recommendations.**

The requirement to move all longlines and anchors to within the relevant licensed site will increase channels between the lines which will improve water flow between the sites.

Reduction of drop rope density (increased space between drop ropes) will improve water flow on the individual site and neighbouring sites which in turn will help improve growth rates. There should be no problem in reducing the number of drop ropes to 800 per Hectare as this will not significantly decrease production in the bay.

Reduction of floatation is needed as there is currently nearly twice the necessary number of floats present to support the biomass. This is leading to increased shake off of mussels in rough weather. As a maximum the total floatation should be limited to 18,000 Litres per Hectare.

A reduction in floatation and drop rope numbers will be required when longlines are moved within sites, otherwise the relative densities within the site will increase which could lead to further problems with growth rates and production.

Thinning and repacking should be encouraged to help reduce overall biomass and improve productivity per licensed Hectare. If this option is not considered then reduction of the density of collection per metre of dropper is required. By doing either of these things the growth rate will improve and it is possible to even increase harvest production for the bay.

At present the worst affected area are the sites in Middle Killary. The above recommendations will help improve the situation. However the movement of some sites from the South side of the bay to the North side without increasing production capacity would potentially improve growth rates etc. Obviously there are legal considerations here that were beyond the scope of the UISCE project. Bearing this in mind, a reconfiguration of sites within Killary should have the effect of allowing better 'buffering' between sites and a consequent increased possibility of food and flow 'recovery' and ultimately better mussel growth. The result of this should be faster and more even growth across aquaculture growing zones.

Certain of the sites in Inner Killary (ones that are 1 square Hectare) cannot fit a standard longline in them with its anchors (most of these sites originally held mussel rafts). Consideration should be given to changing the dimensions of these sites to 200m long by 50m wide to permit the operators to place two longlines in them.

Sites that are currently unused should not be renewed (e.g. T9\_398A) and no new applications for these sites should be considered.

Any equipment not associated with current licences or renewals should be removed.

A monitoring programme in respect of growth rates and production should be established to measure the outcomes of any changes made.

Growers should provide a work programme, giving time scales, for the movement of specific lines and a detailed plan as to how their sites will be laid out in accordance with the licence renewal. If there are problems with other growers lines that are preventing them from moving their own lines then this should be detailed and agreement reached with the other growers on when they are moving the lines. These individual plans should then be incorporated into an overall work programme for the bay with specific deadlines that can be monitored and reported on.

---

